

WG20 Geared Motors - Mounting Instruction



www.mak.nl

P.O. Box 462
8200 AL Lelystad
The Netherlands

T +31 (0)320 - 266966
E info@mak.nl

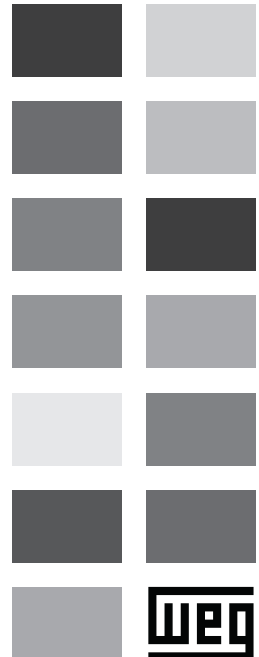
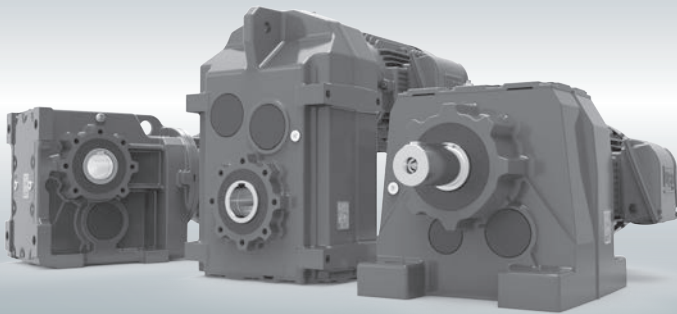

1.	General	E-3
1.1.	Safety and information markings	E-3
1.2.	General information	E-3
1.3.	Exclusion of liability	E-4
1.4.	Indication of copyright and protective right	E-4
2.	General safety	E-5
3.	Gear unit / Geared motor description	E-6
3.1.	Nameplate	E-6
3.2.	Type designation	E-7
4.	Transport	E-8
5.	Storage	E-9
6.	Gear unit construction	E-10
6.1.	Basic design principles helical gear unit C	E-11
6.2.	Basic design principles parallel shaft gear unit F	E-13
6.3.	Basic design principles helical bevel gear unit K	E-15
7.	Mechanical installation	E-17
7.1.	Preparatory work gear unit	E-17
7.2.	Preparatory work motor	E-18
7.3.	Setting up the gear unit / geared motor	E-20
8.	Check list - Gear unit	E-27
9.	Check list - Motor	E-28
10.	Startup	E-28
10.1.	Electrical connection of the motor	E-28
10.2.	Direction of rotation	E-29
10.3.	Oil level in the gear unit as delivered	E-29
11.	Operation	E-29
12.	Malfunction	E-30
13.	Inspection and maintenance	E-31
13.1.	Inspection and maintenance intervals	E-31
13.2.	Inspection and maintenance work on gear unit	E-32
14.	Lubricants	E-33
15.	Mounting positions and lubricant capacity	E-34
15.1.	Helical gear units C	E-34
15.2.	Parallel shaft gear units F	E-36
15.3.	Helical bevel gear units K	E-37
16.	Position of terminal box and cable entry	E-38
17.	Terminal board connection	E-39
17.1.	EUSAS Motors	E-39
17.2.	Multi-Voltage Motors	E-39
17.3.	Connection Diagram	E-39
18.	Optional motor devices	E-41
18.1.	Anti-condensation heating	E-41
18.2.	Drain	E-41
18.3.	Forced cooling	E-41
18.4.	Temperature controller Bimetal switch „NC contact“ (TH)	E-42
18.5.	PTC Thermistor protection (TF)	E-42
18.6.	Brake	E-42
19.	Table of Tightening Torques	E-46
20.	Disposal	E-46
21.	Declaration of incorporation	E-47
22.	EU declaration of conformity ATEX 2014/34/EU	E-48
23.	EU declaration of conformity: low voltage directive 2014/35/EU	E-50

1. General

1.1. Safety and information markings

All safety and warning instructions must be followed without exception!



WARNING!

Warning of electrical or mechanical danger



ATTENTION!

Important instructions for safe and trouble-free operation



ATEX!

Important information on explosion protection

1.2. General information

This Mounting Instruction (MI) is part of the gear unit as supplied and must be read carefully before working with the gear unit. The instructions in the MI must be followed. Keep the MI close to the gear unit.

We assume no liability for damages or disruptions of operations resulting from the failure to observe this MI.

In order to develop the product further, the producer reserves the right to make modifications to the individual components or assemblies that are believed to be useful to improve the product, while maintaining its essential characteristics.

Protection class:

The gears are in accordance with Protection Class IP 65.

Motors are designed within Protection Class IP 55 at minimum (see nameplate).

Intended use:

The gears / geared motors are exclusively assigned for the generation of a defined rotary motion within machinery and plants. The gears comply with the basic requirements of the machinery directive 2006/42/EC as far as possible.

Any other use or utilisation above this is deemed a not intended use. The user / operator of the machine / plant is solely liable for damages resulting therefrom.

The details in this mounting instruction, on the nameplate as well as in other technical documentation, are to be considered and observed.

Intended use for motors:

The motors comply with the basic requirements of the Low Voltage Directive 2014/35/EU. They are designed for power operating as well as operating in combination with frequency inverters.

Standard motors are designed for use at:

- Ambient temperatures of -20°C (-4°F) to +40°C (104°F)
- Altitudes of ≤ 1,000 m above sea level



ATEX!

Intended use in the ex-area:

WG20 gear units with IEC adapters:

WG20 gear units in ATEX execution meet valid standards and specifications as well as the requirements according to Directive 2014/34/EU. Motors, that are not approved for the ex-area, must not be connected to WG20 gear units, when used in hazardous areas.



The explosion proof gear unit types

- C...Helical gears
- F...Parallel shaft gears
- K...Helical bevel gears

meet the design specifications of

- Equipment group II, Category 2G+2D (Zone 1+21)
- Equipment group II, Category 3G+3D (Zone 2+22)

WG20 geared Motors:

WG20 geared motors in ATEX execution meet valid standards and specifications as well as the requirements according to Directive 2014/34/EU.

The explosion proof geared motor types

- C...Helical geared motors
- F...Parallel shaft geared motors
- K...Helical bevel geared motors

meet the design specifications of

- Equipment group II, Category 3G+3D (Zone 2+22)

Ambient temperature:

WG20 gear units and geared motors used in ATEX execution may only be used in areas with ambient temperatures between -20 °C and +40 °C.

Altitude:

≤ 1000 m (above sea level)

1.3. Exclusion of liability

You must comply with the information contained in this MI to ensure safe operation of the gear unit, geared motor and to achieve the specified product characteristics and performance requirements.

The producer assumes no liability for injury to people or damage to equipment or property resulting from non-observance of this MI. In such cases, any liability for defects is excluded.

1.4. Indication of copyright and protective right

All technical documents are protected in the sense of the copyright law. The processing, reproduction and dissemination of it, even in extracts, as well as other utilisation is not allowed, unless it has been expressly conceded in written form.

2. General safety

The customer is responsible for setting up the drive in accordance with good engineering practices.

The instructions in this Mounting Instruction must be followed to achieve the confirmed characteristics of the drive units and to ensure approval in case of warranty claims.

Make certain that you never put damaged products into operation!

Read this Mounting Instruction carefully before you begin any setup, installation or maintenance work.

Installation, start-up, maintenance and repair work on the gear unit / gear motor as well as on electrical accessory equipment may only be performed by qualified technical personnel, taking the following items into account:

- Operating Instructions
- Information labels/tags on the gear unit / geared motor
- All other project documents, setup manuals, operating manuals
- Drive-specific specifications and requirements belonging to the drive unit
- The applicable regional and national regulations on safety and accident prevention



WARNING!

Work is only permitted:

- *on the stationary drive,*
- *while disconnected and*
- *prevented from being switched on again.*

Operation of the drive unit by means of a frequency inverter may only occur if the specifications shown on the motor nameplate have been carried out.



ATEX!

The use of gear units / geared motors in gas mixtures or dust concentrations, that are capable of exploding in combination with hot, load bearing and moving parts, can result in death or serious injury.

3. Gear unit / Geared motor description

3.1. Nameplate

All data on the nameplate of the gear defines the limits of its intended usage. It is imperative to adhere to this data.

Please take further technical data and drawings from the latest geared motor catalogue.

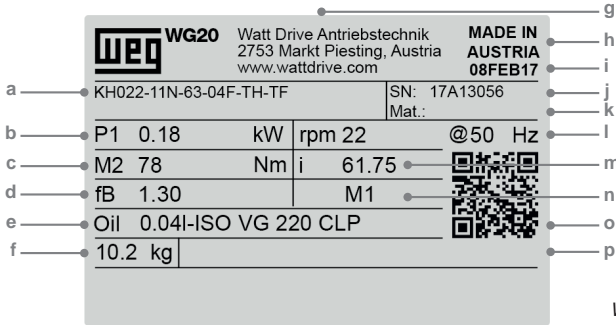

WG20 nameplate (example)

a	Type code	i	Production date
b	Motor power	j	Serial number
c	Output torque	k	Material number
d	Service factor	l	Output speed and Frequency
e	Oil quantity and type	m	Total gear ratio
f	Weight	n	Mounting position
g	Producer	o	QR code with link to additional data
h	Production country	p	Space for additional information

ATEX!

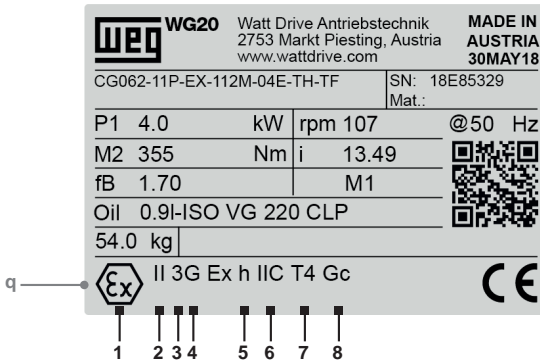

Nameplate for WG20 gear units in ATEX execution (example)

q	ATEX code	
	Directive ATEX 2014/34/EU	Standard EN ISO 80079-36/-37
1	Ex symbol	5 Type of protection
2	Equipment Group	6 Explosion group
3	Equipment Category	7 Temperature Class / max. surface temperature
4	Atmosphere	8 Equipment Protection Level (EPL)

3.2. Type designation

Type designation (example)	CG02-11N-63-04F-TH-TF-BR2	FH032-11P-80-04F-TH-TF-BR8	KH022-11N-63-04F-TH-TF
Type	C (Helical gear unit)	F (Parallel shaft gear unit)	K (Helical bevel gear unit)
Possible gear unit execution	CA ... Foot and flange type with output shaft CF ... B14-flange housing with output shaft CG ... Flange type with output shaft CW ... Foot and B14-flange type with output shaft	FD ... Hollow shaft and shrink disc FF ... B5-flange type with output shaft FH ... Hollow shaft FO ... B5-flange type with hollow shaft FP ... B5-flange type with hollow shaft and shrink disc FS ... Output shaft FT ... Hollow shaft with rubber buffer FU ... Hollow shaft with shrink disc and rubber buffer	KD ... Hollow shaft and shrink disc KF ... B5-flange type with output shaft KH ... Hollow shaft KO ... B5-flange type with hollow shaft KP ... B5-flange type with hollow shaft and shrink disc KS ... Output shaft KT ... Hollow shaft with torque arm KU ... Hollow shaft with shrink disc and torque arm
Possible gear unit sizes	00, 01, 03, 05, 06, 07, 08, 09, 10, 13, 14, 16	02, 03, 04, 05, 06, 07, 08, 09, 10, 12, 15	02, 03, 04, 05, 06, 07, 08, 09, 10, 12, 15
Possible gear stages	00, 01: 2 stages 03-16: 2 or 3 stages	02, 03: 2 stages 04-15: 2 or 3 stages	02: 2 stages 03-15: 3 stages

Gear unit input types	
63... - 250...	Motor frame size
I..	IEC adapter
N..	NEMA adapter
S..	SERVO adapter
U..	Input unit

Optional additional motor devices	
Type designation (example)	11P 100L-04F SH K1 KB MIP BRH32 FL SD
11P 100L-04F	Motor type
TH, TF, KTY	Temperature control
FL	Forced cooling
IG, SG	Encoder
BR..	Brake
BBR..	Double brake
BRH..	Brake with manual release
BRHA..	Brake with manual release and locking device
KKM, RSM	Back stop
U, UW	Unventilated
KB	Drain
SH	Anti condensation heating
K1, K2	Climatic protection
MIP, MIG	Terminal box design
SD	Protection cap
HR	Hand wheel
ZM	Metal fan
ZL	Fly wheel fan
ZWM, ZWV	Second shaft end

4. Transport

After delivery, the unit must be inspected for any damage that may have occurred during transport. In case of damage do not put the motor into operation.

ATTENTION!

To lift the geared motors, you have to use the following load handling equipment:

Helical geared motors C				
	Gear size	Motor size	Load handling	
		C00 C01	all	No equipment for load handling provided
C03 C05 C06		63 - 71	No equipment for load handling provided	-
		80 - 90	Lifting eye on the gearbox	1
C07 C08 C09 C10 C13 C14 C16		100 - 132	Lifting eye on the gearbox + eye bolt on motor (max. angle of 60° between the ropes)	2
		63 - 90	Lifting eye on the gearbox	1
		100 - 250	Lifting eye on the gearbox + eye bolt on motor (max. angle of 60° between the ropes)	2

Parallel shaft geared motors F				
	Gear size	Motor size	Load handling	
		F02	all	No equipment for load handling provided
F03 F04 F05		63 - 71	No equipment for load handling provided	-
		80 - 90	Support hole	1
F06 F07 F08 F09 F10 F12 F15		100 - 132	Support hole + eye bolt on motor (max. angle of 60° between the ropes)	2
		63 - 90	Support hole	1
		100 - 250	Support hole + eye bolt on motor (max. angle of 60° between the ropes)	2

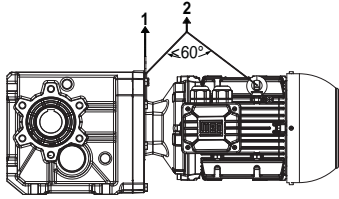
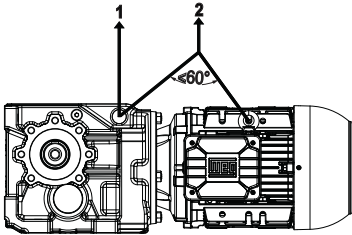
Helical bevel geared motors K				
	Gear size	Motor size	Load handling	
		K02	all	No equipment for load handling provided
K03 K04 K05		63 - 71	No equipment for load handling provided	-
		80 - 90	Lifting eye on the gearbox	1
		100 - 132	Lifting eye on the gearbox + eye bolt on motor (max. angle of 60° between the ropes)	2
K06 K07 K08 K09 K10 K12 K15	63 - 90	Lifting eye on the gearbox	1	
	100 - 250	Lifting eye on the gearbox + eye bolt on motor (max. angle of 60° between the ropes)	2	

5. Storage

General:

The following items must be taken into account when storing the gear units:

- In general, the drive units must be stored in closed rooms.
- Ambient temperature max. 25°C (77°F)
- Relative humidity max. 80 %
- The drive units are to be protected from exposure to the sun or UV light.
- No aggressive or corrosive materials are to be stored in the vicinity of the unit.
- The gear units are to be stored in the same position that is intended for a later use.
- The gear units are to be rotated 1-2 revolutions on the output side every 6 months to ensure that the interior parts are wetted with lubricant.
- The units are to be protected from mechanical loads and exposure to outside forces.

Long-term storage:

- When the gear units are to be stored for longer than 12 months, they must be completely filled with lubricant as stated on the nameplate or lubricant plate.
- Unfinished, bare-metal parts on the outside of the unit are to be protected with a corrosion protection product (inspection every 6 months is recommended). The corrosion protection must be replaced after one year.
- Before starting the gear unit, drain the lubricant from it. If more than one lubricant chamber is present, make certain that all of the lubricant chambers have been drained out.
- Gaskets settle, especially after a longer period without loading. Before starting, the screws must be retightened.
- Then fill the gear unit with the lubricant type specified on the nameplate using the specified quantity.
- If the gear units are stored for longer than 24 months before being put into service, they must be checked for leaks. If there are any visible cracks on the surfaces of sealing elements, such parts must be replaced.

6. Gear unit construction

The following drawings basically show the construction of the various dry series in theory. Deviations from other gear unit sizes and design versions are possible per gear unit series.

Legend for the construction drawings:

Position		Description	Position		Description
01	00	Kit Housing	04	00	Kit Output pinion shaft
01	01	Housing	04	01	Output pinion shaft
01	02	Gasket housing/motor adapter	04	02	Bearing 3
01	03	Pin	04	03	Bearing 4
01	04	Housing gasket	04	04	Circlip
01	05	Inspection cover	04	05	Bearing cover
01	06	Inspection cover screw	04	06	Shim washer
01	07	Copper ring	04	07	Adjusting washer
01	08	Plug	04	08	Bearing 5
01	09	Vent plug	04	09	Shaft/Gear key/pin
01	19	Stopper	04	11	Shim washer
01	20	Kit Case cover/Motor adapter	04	18	Distance sleeve
01	21	Case cover/Motor adapter	04	19	Distance sleeve
01	22	Motor gasket	04	20	Kit Bearing carrier
01	23	Motor screw	04	21	Bearing carrier
01	24	Case cover screw	04	22	Bearing 5
01	25	Case cover screw	04	23	Bearing 6
01	26	Pin screw	04	24	Circlip
01	27	Hexagon nut	04	25	Distance sleeve
01	50	Lifting eye/Ring screw	04	26	Screws
02	00	Kit Output shaft	04	27	Adjusting washer
02	01	Output shaft	04	28	Shim washer
02	02	Bearing 1	04	29	Circlip
02	03	Bearing 2	04	30	Shim washer
02	04	Shaft sealing 1	04	31	1st stage gear key/pin
02	06	Shaft/Gear key	04	39	Shim washer
02	07	DE key	04	40	Conical/Hole pinion
02	08	Circlip 1	04	50	1st stage gear/Intermediate gear
02	09	Distance sleeve	05	00	Kit Output flange
02	10	Bearing cover	05	01	Output flange
02	11	Adjusting washer	05	02	Flange screw
02	12	Shrink disc	05	03	Gasket
02	13	Glycodur bush	05	10	Kit Torque arm
02	14	Shim washer	05	11	Torque arm
02	15	Shim washer	05	12	Silent block
02	16	Circlip 2	05	13	Bushing
02	17	Clamping bushing	05	14	Screw
02	18	Support bushing	05	20	Kit Rubber buffer set
02	50	Output gear	05	21	Rubber buffer
03	00	Kit intermediate pinion shaft	05	22	Shim/Spring plate
03	01	Intermediate pinion shaft	05	30	Kit Shaft cover
03	02	Bearing 5	05	31	Shaft cover
03	03	Bearing 6	05	32	Gasket
03	04	Circlip 1	05	33	Screw
03	05	Circlip 2	05	40	Kit Hollow shaft fixing kit
03	06	Bearing cover	05	41	Disc
03	07	Shim washer	05	42	Circlip
03	08	Adjusting washer	05	43	Screw
03	09	Shaft/Gear key	11	00	Motor
03	13	Circlip	11	10	Slinger
03	20	Bevel pair	11	11	Motor shaft/Hole pinion key
03	21	Shaft for bevel gear			
03	22	Circlip for bevel pinion			
03	23	Bevel pinion key			
03	50	1st stage gear			

6.1. Basic design principles helical gear unit C

Gear sizes C00 to C06

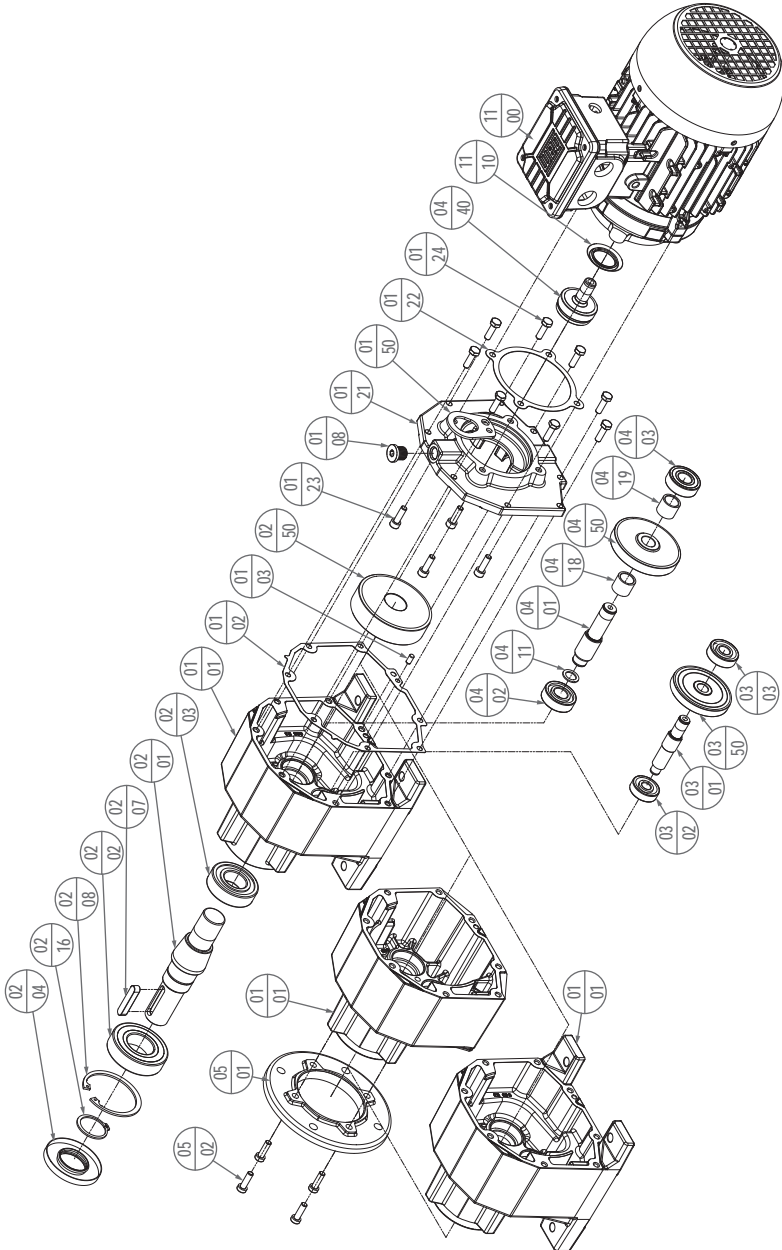

Gear sizes C07 to C16

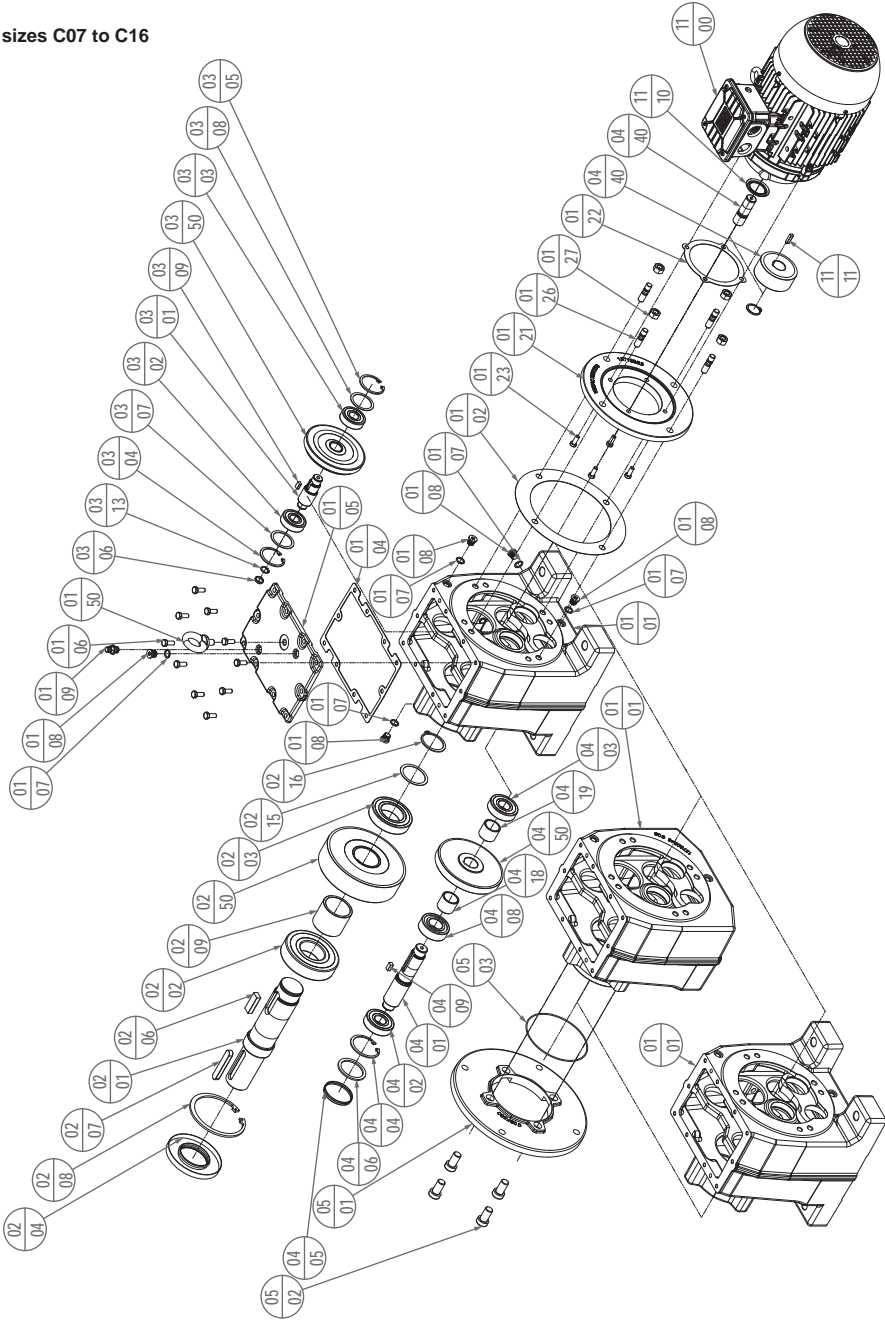

6.2. Basic design principles parallel shaft gear unit F

Gear sizes F02 to F05

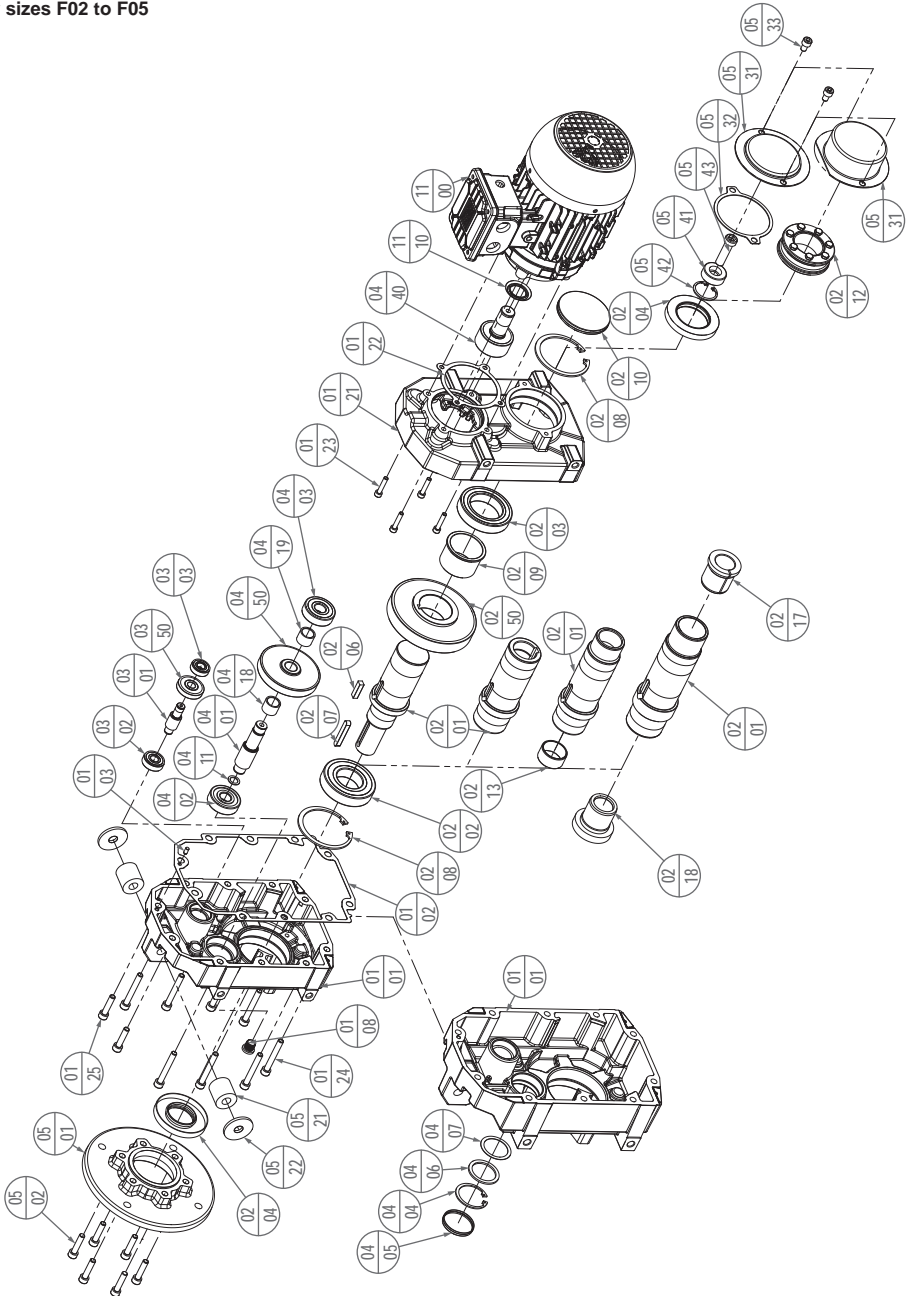

Gear sizes F06 to F15

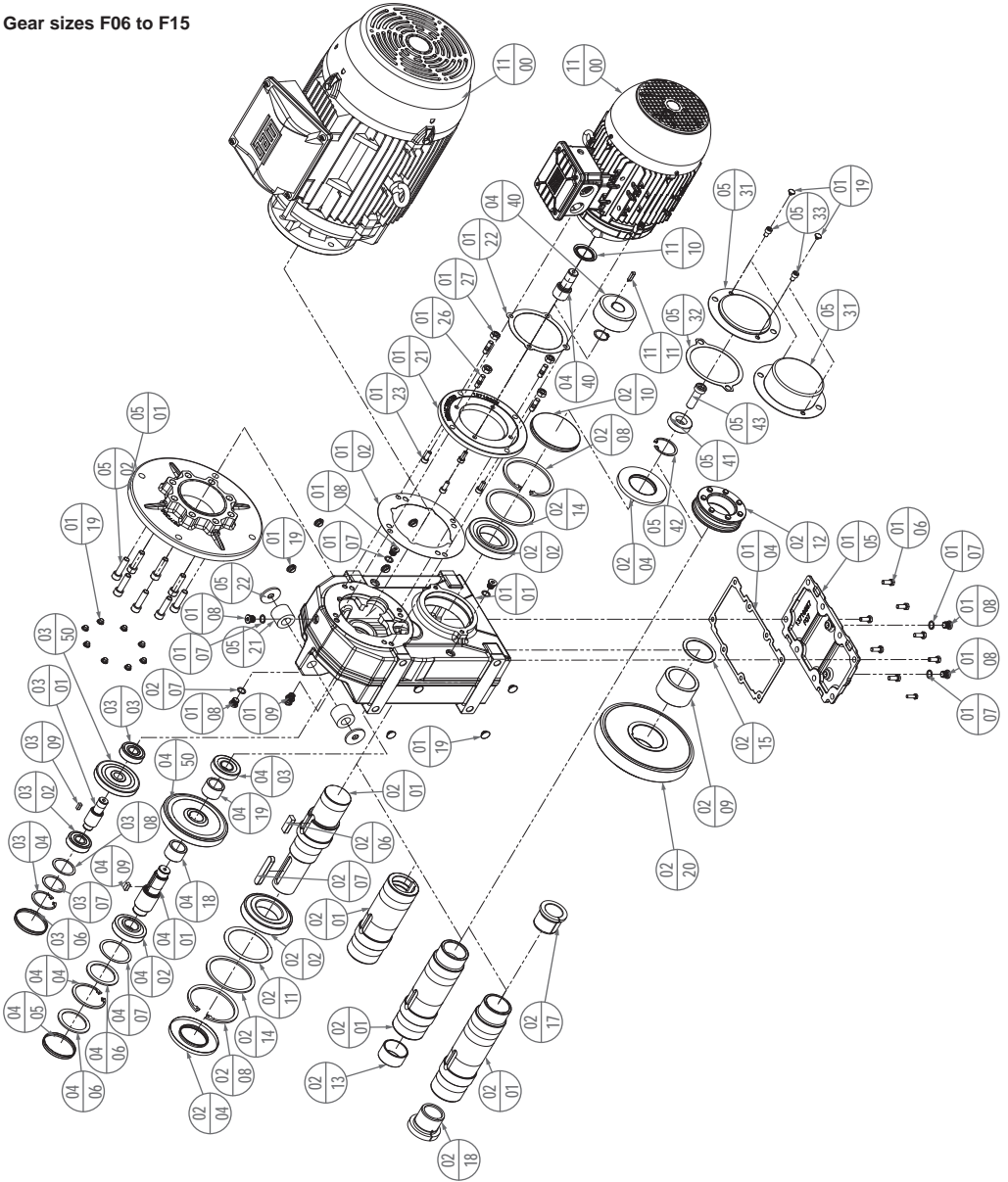

6.3. Basic design principles helical bevel gear unit K

Gear sizes K02 to K05

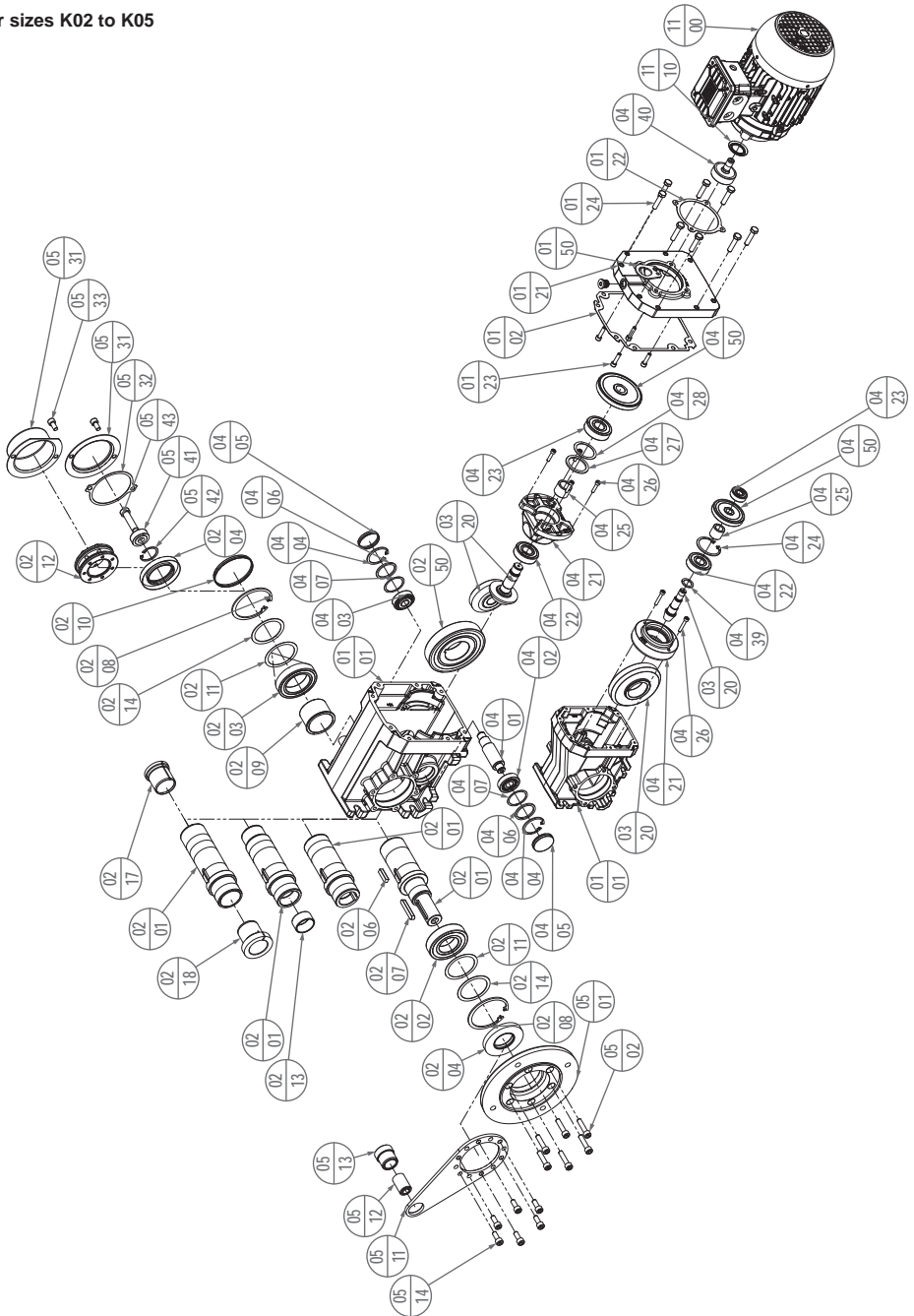

Gear sizes K06 to K15

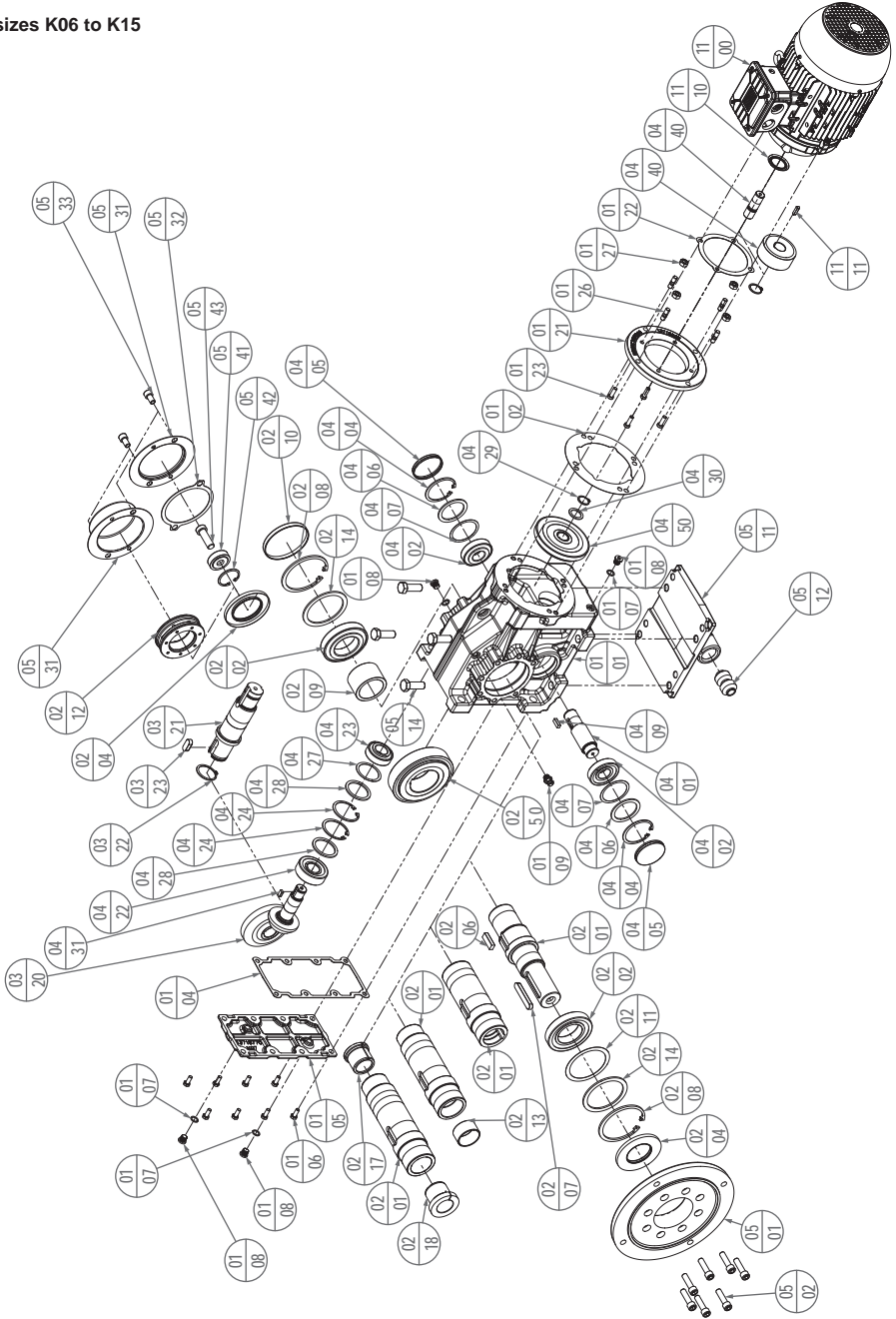

7. Mechanical installation

7.1. Preparatory work gear unit

7.1.1. Inspecting the gear unit

The gear unit must not be put into operation unless:

- no damage caused, for example, by storage or transport, is apparent.
- in particular, the shaft seals, cover caps, and guard hoods are not damaged.
- no leaks or loss of oil are visible.
- no corrosion or other indication of improper storage or storage under damp conditions is present.
- all of the packaging materials were removed.
- oil drain plugs and vent plugs must be fully accessible!

As a general rule, drive shafts and flange surfaces must have all corrosion protection products and dirt cleaned from them, standard commercial solvents can be used.



ATTENTION!

*The sealing lips on the shaft seals must not be allowed to come in contact with the solvent!
Material can be damaged!*



ATEX!

The gear unit may only be put into operation, if

- the ambient conditions on location are according to the requirements on the nameplate of the gear unit (Equipment group, Category, Zone, Temperature class, maximum ambient temperature).
- the ambient atmosphere is not explosive when mounting the drive.
- attached drive elements, like couplings, pulleys, etc. as well as mounted motors are ATEX compliant.
- permissible radial and axial forces for the gear unit have been considered.
- no damages of the gear unit are apparent.
- no leaks or loss of oil are visible.

7.1.2. Mounting position

The gear unit may only be operated in the specified mounting position, which may be found on the nameplate. The mounting position must not be changed during operation.



ATEX!

A change of the mounting position may only be performed after consultation with the producer. Changing the mounting position without consultation will render the Declaration of Conformity invalid and will exclude you from any warranty claims.

7.1.3. Torque support by means of rubber buffer

Every Urelast spring must be mounted with a pre-stressing of 2 mm (F02, F03) or 3 mm (from F04).

7.1.4. Painting the gear unit

If the gear unit will be painted or partially repainted, make certain that the vent plug and the shaft seals are carefully masked. Remove the masking tape after the painting work is completed.



ATEX!

Gear units and geared motors (Zone 2+22) with painting plans from LC3 and higher are equipped with notification signs regarding electrostatic charge:



7.1.5. Housing surface temperature

In order to prevent excessive heating of the gear unit, the following must be observed:

- Sufficient clearance must be provided around the gear unit.
- The cooling air for gear unit motors must be able to flow unhindered around the gear unit.
- The gear unit must not be completely boxed in with a housing.
- The gear units must not be exposed to hot exhaust air from other units.

No heat must be transferred into the gear unit.

7.2. Preparatory work motor

7.2.1. Terminal box

It must be ensured that there are no foreign bodies, dirt or moisture in the terminal box. Open entries are to be sealed with an O ring or a suitable flat gasket so that dust and water cannot enter, whereas the terminal box itself is to be sealed against dust and water with the original seal.

It must be ensured that the terminal box, terminal board and cable connections etc. inside the terminal box are not damaged!



WARNING!

The terminal box must be sealed so that dust and water cannot enter!

7.2.2. Checking the insulation resistance

The insulation resistance needs to be checked prior to start-up and again after any extended periods of storage or periods during which the equipment is not in operation!

Before you begin measuring the insulation resistance, please read the manual for the insulation resistance meter you are going to use. Any cables of the main circuit, which are already connected, should be disconnected from the terminals in order to carry out the insulation measurements.



WARNING!

During the measurement, and immediately afterwards, some of the terminals are at hazardous voltage levels and must not be touched. Carry out a check with the power cables connected that no voltage can be applied.

Where possible, measure the minimum insulation resistance of the winding to the motor enclosure when the winding temperature is between +20 °C and +30 °C. For other temperatures, different values apply to the insulation resistance. When taking the measurement, you must wait until the final resistance value is reached (approximately 1 minute).

ATTENTION!

If the critical insulation resistance is less than or equal to this value, the windings must be dried or, if the fan is removed, cleaned thoroughly and dried. Note that the insulation resistance of dried, clean windings is lower than that of warm windings. The insulation resistance can only be properly assessed after conversion to the reference temperature of +25 °C. If the measured value is close to the critical value, you must subsequently check the insulation resistance at appropriately frequent intervals.

The following Table 1 indicates the measuring circuit voltage together with the minimum insulation resistance and the critical insulation resistance. Values apply at a winding temperature of +25 °C.

Table 1: Insulation resistance

	Rated voltage $U_{\text{rated}} < 2 \text{ kV}$
Measuring circuit voltage	500 V
Minimum insulation resistance with new, cleaned or repaired windings	10 MΩ
Critical specific insulation resistance after a long operating time	0.5 MΩ/kV

Also note the following points:

- When measuring at winding temperatures other than +25 °C, the measured value must be converted to the reference temperature of +25 °C. The insulation resistance is reduced by a factor of a half for every 10 K increase in temperature, and it is increased by a factor of two for every 10 K decrease in temperature.
- New, dry windings have an insulation resistance of between 100 and 2,000 MΩ, or even higher values in some cases. If the insulation resistance is close to or below the minimum value, the cause could be humidity and/or dirt accumulation. The windings must then be dried.
- During operation, the insulation resistance of the windings can fall to the critical insulation resistance due to ambient and operational influences. Depending on the rated voltage, the critical insulation resistance for a +25 °C winding temperature can be calculated by multiplying the rated voltage (kV) by the specific critical resistance value (0.5 MΩ/kV); e.g. critical resistance for a rated voltage (UN) 690 V: $1000 \text{ V} \times 0.5 \text{ M}\Omega/\text{kV} = 0.345 \text{ M}\Omega$

7.2.3. Connecting the ground conductor

The grounding has to be connected in the terminal box at the place intended for this purpose and marked accordingly.

The cross-section of the ground conductor of the machine must comply with the regulations for electrical installations, e.g. DIN EN IEC 60204-1.

Please note the following when connecting-up:

- The contact surface must be clean and bright, and protected with a suitable anti-corrosion agent, e. g. acid-free Vaseline.

Table 2: Minimum surface area

Minimum surface area „S“ of phase conductor (L1, L2, L3) mm ²	Minimum surface area of corresponding ground connection mm ²
$S \leq 16$	S
$16 < S \leq 35$	16
$S > 35$	$0.5 \times S$

ATEX!

Geared motors (Zone 2+22) are delivered with a separate motor manual included in the packaging. The adherence to this manual is imperative for the operation in explosive areas.

7.3. Setting up the gear unit / geared motor

- When installing please ensure that the unit is not exposed to any shocks or vibrations in order to avoid noise during operation.
- The mounting surface should be even and torsionally rigid.
- Distortion of the gear case should also be avoided.
- Reduce reaction torque with a torque arm or a rubber buffer kit (no rigid joints).
- Input and output elements have to be equipped with a contact protection.
- When installing the motor, ensure that the intake is not obstructed and air can circulate freely. Do not remove the fan blade or cowl, or enclose the motor with a casing because in both cases, there would not be enough air for cooling and the motor could overheat.

7.3.1. Gear unit ventilation

Gear unit with vent plug:

Oil drain plugs and vent plugs must be fully accessible!

The vent plug with transport locking device is installed at the proper position for the mounting position.

Following gear unit sizes are equipped with a vent plug:

- C07, C08, C09, C10, C13, C14, C16
- F06, F07, F08, F09, F10, F12, F15
- K06, K07, K08, K09, K10, K12, K15



ATTENTION!

Activating the vent valve:

The vent valve is to be activated before the unit is put into operation by completely demounting the transport protection (rubber clip) as described below.

Figure 1: Information label (red) on the gear unit



Remove the rubber clip completely before start-up!



ATEX!

Without removal of the transport protection or with a dirty valve, the gear unit may overheat. Check the full functionality of the vent valve regularly.

Following gear unit sizes are not equipped with a vent plug:

- C00, C01, C03, C05, C06
- F02, F03, F04, F05
- K02, K03, K04, K05

7.3.2. Geared motor with backstop

The backstop allows the operating in only one rotating direction. The free rotating direction is marked with a rotating direction arrow at the output of the gear or on the ventilation cover of the motor.

ATTENTION!

A start-up of the motor with full power consumption against the locking direction of the gear will lead to destruction or damage of the backstop.

The free rotating direction has to be checked before the start-up.

Geared motor with a backstop at the motor:

Using gears with backstop, the rotating direction of the e-motor and the mains are to be detected with a meter. Mind the rotating direction arrow on the housing! On motors, which are winded 400/690 Volt, the rotating direction can be detected through a short-time start-up in star connection.

7.3.3. Gear unit with solid shaft

The output shafts are manufactured with a diameter of 50 mm in ISO k6 tolerance class and beginning at a diameter 55 mm in ISO m6 tolerance class.

All output shafts are equipped with DIN 332 tapped centre holes that are used to tighten the transfer elements.

All output shafts are provided with a corrosion protection product upon delivery. This product must be removed with a conventional solvent.

ATTENTION!

- *The solvent must not be allowed to come into contact with the shaft seals!*
- *Make certain to prevent all impacts and mechanical shocks on the end of the shaft since the output bearing system can be damaged.*
- *Mechanical drive elements that apply radial forces to the output shaft must be installed as close as possible to the output shaft bearings!*
- *Add-on power transfer elements should balance and must not cause any unacceptable radial or axial forces (see Catalogue for acceptable values).*

7.3.4. Installation and demounting of hollow-shaft gear units

ATTENTION!

Concerning the design of the customer's shaft please mind the construction references in the latest geared motor catalogue.

Assembling: (see Figure 2 and Figure 3 on page E-22)

The hollow-shaft gear units must always be installed in such a way that no axial forces are applied to the output shaft bearing system.

1. Check the machine shaft (3) on possible damages like e.g. notches or upsettings.
2. Clean the customer's machine shaft (3) thoroughly before the mounting.
3. Before tightening the hollow-shaft gear unit onto the machine shaft, paint the surface of the machine shaft with lubricating paste (3) such as Klüber Paste 46MR401.
4. Mount the drive onto the machine shaft (4, 5). An additional distance tube is required for a customer's shaft without contact shoulder.
5. Implement the optionally obtainable fixing set into the hollow shaft and secure the customer's shaft axial with the locking bolt (4). Screw tightening torque see Table 9 on page E-46.
6. The locking bolt should additionally be protected by a threadlock adhesive (medium strength).

Figure 2: Tightening the customer shaft

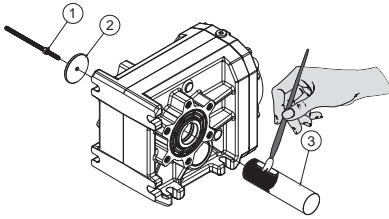

- (1) Threaded rod + hex nut
- (2) Thrust washer
- (3) Customer-side machine shaft

Figure 3: Mounting the customer shaft using a mounting set

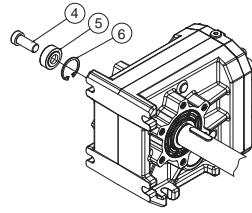

Parts (4), (5) and (6) are included in the optional fixing kit GMBSBSD.

Demounting:

1. Loosen the fixing bolt (4). Remove the complete fixing set and, if existing, the distance tube.
2. Put the pressure disc (11), jack nut (10) and circlip (6) into the hollow shaft.
3. Screw in the fixing bolt (9). Through tightening of the screw you are pressing the gear off the machine shaft (3).

Figure 4: Demounting the customer shaft with or without contact shoulder

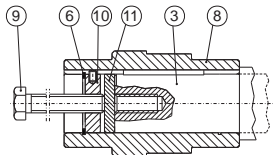

- (3) Customer's shaft with tapped centre hole as per DIN332, sh.1
- (6) Circlip DIN 472
- (8) Hollow shaft
- (9) Retaining screw DIN 933 (to customer specification, length according to machine shaft length)
- (10) Jack nut
- (11) Thrust washer

7.3.5. Installation and demounting of shrink disks

⚠ ATTENTION!

The shrink discs are supplied ready to install. They must not be taken apart prior to the first installation. The tightening of the locking bolts without an implemented customer's shaft can lead to a deformation of the hollow shaft.

Assembling (see Figure 5 on page E-23):

1. Remove the possibly existing cover cap.
2. Loosen the locking bolts (3) with just a few threads. Do not screw them out completely!
3. Thoroughly degrease the entire hollow shaft boring (2, grey area). It must be ABSOLUTELY free of grease!

4. Thoroughly degrease the machine shaft (1, grey area) in the clamping area of the shrink disc. It must be ABSOLUTELY free of grease!
5. Push the shrink disc onto the hollow shaft (2) until the outer ring of the shrink disc is flush with the hollow shaft (2). The outer part of the hollow shaft (2) can be greased in the area where the shrink disc is fitted.
6. Insert the degreased machine shaft (1) into the hollow shaft (2) so that the area of the shrink connection is fully used.
7. Slightly tighten the locking bolts (3) in sequence clockwise with several turns, so that both outer rings (5) are clamped parallel towards each other. The number of locking bolts depends on the size of the shrink disc.

ATTENTION!

Do not tighten the locking bolts (3) „CROSSED“!

8. Tighten the locking bolts (3) with a torque key up to the indicated screwing torque (6) on the shrink disc. After the tightening of the locking bolts (3) there has to be an even gap between the outer rings (5). If it is not the case the shrink disc has to be mounted anew.

ATTENTION!

After installation you can sign the hollow shaft respectively the machine shaft with a marking (use a pencil) to detect a slipping during the initial operation (under load).

Figure 5: Hollow shaft with shrink disc

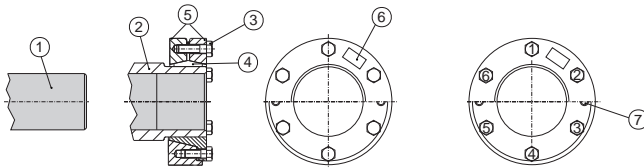

- (1) Customer-side machine shaft
- (2) Hollow shaft
- (3) Locking screw
- (4) Inner ring
- (5) Outer ring
- (6) Tightening torque of the locking screws
- (7) Jack nut

Demounting:

1. Undo the locking screws (3) uniformly and in sequence. Only undo each locking bolt about a quarter turn initially. Do not remove the locking bolts completely.
2. Press the inner ring (4) off using the jack nut (7). Remove any rust beforehand that may have formed on the machine shaft in front of the hollow shaft.
3. Remove the shrink disc from the hollow shaft (2).
4. Step 2 only required for two-part shrink disk execution!

Table 3: Tightening torque of the shrink disc locking screws

Gear unit size	Thread	Tightening torque
F02 / K02	M5	5 Nm
F03 / K03	M6	12 Nm
F04 / K04		
F05 / K05		
F06 / K06		
F07 / K07		
F08 / K08	M8	30 Nm
F09 / K09		
F10 / K10		
F12 / K12	M12	100 Nm
F15 / K15	M14	160 Nm

7.3.6. Installation and demounting of protection cap

Before being installed, the protection caps must be inspected for any damage that might have occurred during transport. Damaged protection caps must not be installed, since they can possibly cause abrasion. All of the fixing bolts are to be used and secured by wetting them with a thread-locking adhesive (medium strength). Bolt tightening torque see Table 9 on page E-46.

Figure 6: Protection cap for hollow shaft

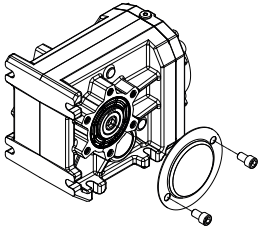
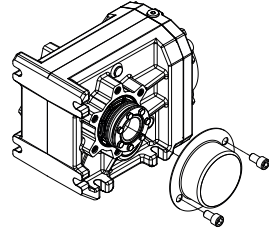

Figure 7: Protection cap for shrink disc hollow shaft



Ex ATEX!

Gear units with hollow shaft, that are used in explosive areas, have to be equipped with a protection cap.

7.3.7. Installation of torque arms

ATTENTION!

Pay attention to the direction of rotation of the hollow shaft!

The Urelast springs in the rubber buffer set are to be loaded under compression in the main working direction of rotation!

Recommended pre-loading of the Urelast spring: 2 mm (F02, F03) or 3 mm (F04, F05, F06, F07, F08, F09, F10, F12, F15)

Figure 8: Parallel shaft gear unit

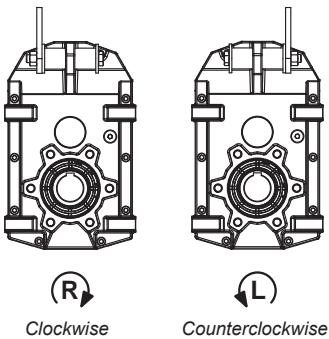

Figure 9: Helical bevel gear unit K02 - K05

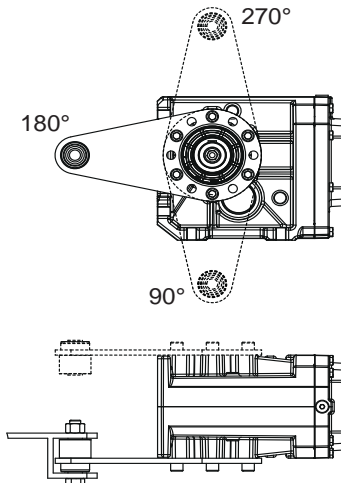
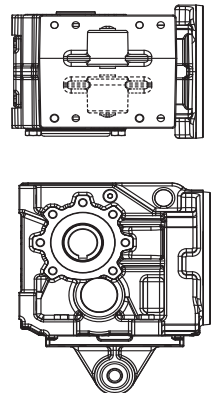

Figure 10: Helical bevel gear unit K06 - K15



Possible positions of the torque arm:
 K02: 90°, 135°, 180°, 225°, 270°
 K03 - K05: 90°, 120°, 150°, 180°, 210°, 240°, 270°

7.3.8. Mounting of IEC/NEMA standard motors with IEC/NEMA adapters

Assembly procedure for IEC standard motors (B5) and IEC plug-in adapters I63 to I100:

Assembly procedure for NEMA standard motors (C-face) and NEMA plug-in adapters N56 to N182:

- Clean the motor shaft and the flange surfaces of the motor and the adapter and check for damages.
- Before installing, apply lubrication paste, e. g. Klüberpaste 46 MR 401, to the motor shaft.
- Wet the retaining screws with thread-locking adhesive (medium strength).
- The contact surface between motor and adapter has to be sealed with appropriate sealant (e.g. Loctite 510 or silicone).
- Then place the motor on the adapter and tighten the bolts (not included) to the specified torque.
- Use bolts with minimum property class 8.8. Tightening torque see Table 9 on page E-46.

Figure 11: Mounting an IEC motor on the plug-in adapter

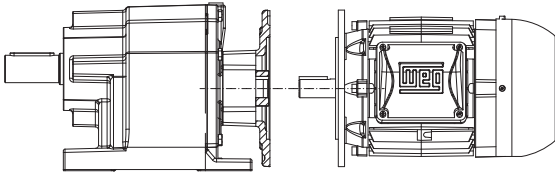

Assembly procedure for IEC standard motors (B5) and IEC adapters I112 and I132 with geared coupling or IEC adapters I160 to I280 with claw coupling:

Assembly procedure for NEMA standard motors (C-face) and NEMA adapters N184 and N213/215 with geared coupling or NEMA adapters N254/256, N284/286, N324/326 and N364 with claw coupling:

The correct assembly position must be observed when fitting the supplied half coupling onto the motor shaft.

- Clean the motor shaft and the flange surfaces of the motor and the adapter.
- Heat the half coupling to approx. 80 °C (176 °F).
- Fit the half coupling onto the motor shaft (coupling flush with the end of the motor shaft ③).
- Secure the key and the fitted half coupling with a set pin by using thread-locking adhesive (medium strength).
- Check that the half coupling is seated correctly.
- The contact surface between motor and adapter has to be sealed with appropriate sealant (e.g. Loctite 510 or silicone).
- Fit the motor onto the adapter. The gearing of the half coupling must fit into the gearing of the coupling bush.
- Fasten the motor onto the adapter using appropriate fastening screws (not included). Tightening torque see Table 9 on page E-46. Minimum property class 8.8.

Figure 12: Mounting an IEC motor on the coupling adapter

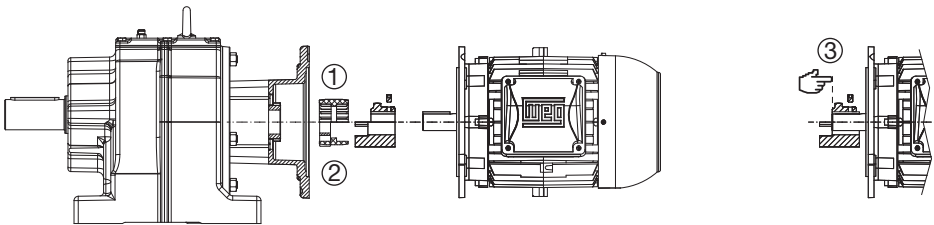

- ① Geared coupling ② Claw coupling

ATEX!

- Only IEC motors with approval for the respective ATEX zone, according to the nameplate, may be mounted.
- The contact surface between motor and adapter has to be sealed with appropriate sealant (anaerobic surface seal, like Loctite 510 or Terostat 9140).

7.3.9. Mounting of SERVO motors

Servo adapters of the WG20 gear unit line are delivered with elastic servo couplings. They ensure silent operation without friction and maintenance-friendly handling.

Concentricity of the shaft ends and true-running of the mounting flanges „N“ (normal) must be according to DIN 42955.

Assembly procedure:

- Clean the motorshaft with a grease remover.
- Remove the coupling hub from the adapter housing. (The coupling star remains in the 2nd half of the coupling, which is built into the adapter.
- Check the insertion diameter of motor shaft and coupling hub.
- Slide the hub onto the motor shaft (Attention: in order to ensure safe operation, adhere to the parameter "X" in Table 4 on page E-26.



ATTENTION!

Incorrect mounting of the hub can lead to excessive abrasion, restraint and subsequently to increased operation temperature!

- Tighten the hub using the included screw. Adhere to the tightening torque in Table 4.
 - Check the correct position of the coupling star inside the adapter.
 - Carefully slide the motor onto the adapter.
- The two coupling halves must connect smoothly!**
- Screw the motor onto the adapter housing. Fastening screws are not included.

Table 4: Correlation of screws / torques according to adapter sizes

Adapter size	Motor shaft diameter [mm]	X [mm]	Type of coupling	Fastening screw (ISO 4762)	Tightening torque [Nm]*
S92	14	47.5	EK7/20	M5	8
	16	47.5	EK7/20	M5	8
	19	47.5	EK7/20	M5	8
S105	19	69.5	EK7/60	M6	15
S114	19	69.5	EK7/60	M6	15
	24	69.5	EK7/60	M6	15
S115	24	69.5	EK7/60	M6	15
S130	19	78.5	EK7/60	M6	15
	22	78.5	EK7/60	M6	15
	24	78.5	EK7/60	M6	15
	28	78.5	EK7/60	M6	15
S141	24	69.5	EK7/60	M6	15
S142	32	77.2	EK2/150	M8	35
		91.2			
S180	35	86.5	EKL/300	M10	70
S189	32	91.2	EKL/150	M10	70
	38	80.5	EKL/300	M10	70
S190	38	107.5	EKL/300	M10	70

* Tightening torque is valid for motors with or without key

Figure 13: Mounting schematics for SERVO motors with key

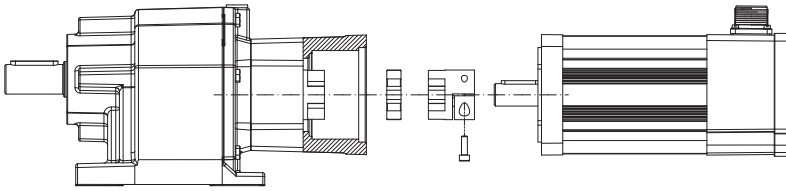
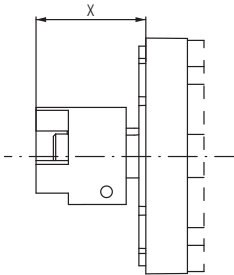

Figure 14: Shaft mounting dimension "X" for SERVO motors



8. Check list - Gear unit

Check the following before starting up the gear unit:

	Information see chapter	Check
Inspect the shipment immediately after reception for any transport damages. In some cases, it may not be advisable to start up the unit.		
Does the mounting position on the nameplate correspond to the actual mounting position?	3.1., 15.	
Is the vent plug located at the correct location (in compliance with the installation position) and freely accessible?	15.	
Is the vent plug activated (rubber flap removed)?	7.3.1.	
In the case of a shrink disc version: has the expansion been checked?	7.3.5.	
Has the free rotating direction been checked when using a backstop?	7.3.2.	
Is protection provided around rotating parts to prevent contact with them?		

Check the following before starting up the gear unit:	Information see chapter	Check
Does the data on the nameplate of the gear unit concur with the ambient conditions on the site of operation?	3.1	
Has it been ensured that there is no explosive atmosphere, oil, acid, vapor or radiation present when mounting the gear unit?	7.1	
Has it been ensured that the gear units are adequately ventilated and that there is no heat from the outside transferred inside (via a coupling, etc.)? Ventilating air temperature must not be more than 40°C.	7.1	
Do all input and output elements have an ATEX approval?	7.1	
Does the motor have an appropriate ATEX approval?	7.3.8.	
Mains operation: Does the data on the nameplate concur with the conditions on the site of operation?		
Frequency inverter operation: Is the geared motor approved for frequency inverter operation? Do the inverter settings correspond with the parameters on the nameplate?		

9. Check list - Motor

Check the following before starting up the motor:	Information see chapter	Check
Check that the mains voltage and frequency correspond to the data on the motor rating plate?		
All connections have been made properly (motor connection, ground conductor, etc.)?	7.2.3.	
Is the direction of rotation of the motor/geared motor correct?	10.2.	
Has the free rotating direction been checked when using a backstop?	7.3.2.	
Is the terminal box dust and watertight?	7.2.1.	
Is a motor circuit breaker installed?	10.1.	
Is all motor protection equipment active and set for the rated motor current?		
Has the insulation resistance been checked?	7.2.2.	
Optional anti-condensation heating is switched off?	18.1.	
Optional forced cooling is connected to an external power supply?	18.3.	

10. Startup

10.1. Electrical connection of the motor

The mains voltage and the mains frequency must match the data on the nameplate. Voltage deviations of $\pm 5\%$ and/or frequency deviations of $\pm 2\%$ are allowable..

ATTENTION!

Connect the motor only as shown in the wiring diagram included in the terminal box of the motor.

The wiring diagram for the motor series 11 and 22 is available in this manual in Figure 17 on page E-40. Connections must be made in such a way as to ensure that a permanently safe electrical connection is maintained (no protruding wire ends); use the corresponding cable end pieces.

 **ATTENTION!**

A motor circuit breaker or contactor with an overcurrent relay should be installed to prevent the motor winding from burning out. Fuses do not stop the motor overloading, but merely protect the power cables or switchgear from damage in the event of a short circuit. Before energizing the motor, always make sure that the optional anti-condensation heating is switched off.

10.2. Direction of rotation

The standard motors are suitable for clockwise and counter-clockwise rotation. Connection of the power cables in the phase sequence L1, L2, L3 to U1, V1, W1 results in clockwise rotation (looking at the shaft end on the drive side).

If two connections are interchanged, this results in counterclockwise rotation (e.g. L1, L2, L3 to V1, U1, W1).

10.3. Oil level in the gear unit as delivered

 **ATTENTION!**

The proper oil level for the mounting position is designed by the plant. See gear unit nameplate for the precise amount of oil to add.

Gear units that are ordered without oil filling are supplied with internal rust proofing consisting of anti-corrosion oil. The anti-corrosion oil can however be mixed with the recommended lubricant indicated on the nameplate. This means that the unit does not have to be flushed before filling with oil.

 **ATTENTION!**

A change in the mounting position must not be made before consulting the producer.

If the gear unit is opened, for example: to make repairs, it must be filled with the correct lubricant in the correct amount as stated on the nameplate before being put back into service. For lubricants see page E-33.

11. Operation

During the operation, the gear unit must be tested under maximum load for:

- unusual noises,
- vibrations and unusual oscillations,
- smoke formation,
- leaks.
- With shrink disc types: After demounting the cover cap, check whether any relative movement has occurred between the hollow shaft and the machine shaft. Then reinstall the cover guard.
- Maximum gear housing temperature 90 °C.

Gear housing temperature:

During the operation, the surface temperature must be measured in the maximum operating condition. The max. surface temperature is reached in about 3 hours, and it must not exceed **90 °C**.

The surface temperature shall be measured with standard commercially available temperature-measuring instruments.

 **ATTENTION!**

The drive must be shut down if any abnormalities relative to the items listed above have been noted upon inspection. Contact the producer.

12. Malfunction

Please provide the following information if help is needed:

- Data from the nameplate
- Type of problem
- Time the problem occurred and circumstances accompanying the problem
- Possible cause

ATTENTION!

Incorrect work on the gear or motor can lead to damages. Should errors emerge at the gear or gearbox, the drive has to be stopped immediately!

Possible malfunctions on the gear unit:

Malfunction	Possible cause	Settling
Unusual, even operating noise.	Bearing damage, gearing damage.	Consult the producer.
Unusual, uneven operating noise.	Foreign object in the oil.	Perform an oil change.
Movement of the gear unit during switch-on.	Gear unit fixation has loosened.	Tighten the fixing bolts and nuts with prescribed screwing torque. Change damaged fixing bolts and nuts.
	Rubber buffer set at the torque support is not pre-stressed or damaged.	Pre-stress the rubber buffer set correctly or change the damaged rubber buffer set.
Gear unit gets too warm (Gear surface temp. > 90°C).	Too much oil.	Correct the oil filling capacity.
	Gear unit damage (gearing, bearing).	Consult the producer.
	Vent plug is defective.	Change the vent plug.
Oil leakage at the gear unit or motor.	Gasket is damaged.	Check gaskets, change them if necessary.
	Gear unit is not ventilated.	Remove the transport lock at the vent plug.
Oil leakage at the vent plug.	Too much oil.	Correct the oil filling capacity.
	Gear unit is operated with the wrong type.	Mount the vent plug at the correct position. Adjust the oil filling capacity according to the type.
	Vent plug is defect.	Change the vent plug.
The gear unit output shaft does not turn though the motor runs or the drive shaft is being turned.	Breakage in the gear unit or shaft hub connection disrupted.	Consult the producer.
	Shrink disc connection slips through.	Check the shrink disc connection.

13. Inspection and maintenance

Gear units of the model range C (sizes 00 to 06), F (sizes 02 to 05) and K (sizes 02 to 05) are **maintenance-free**, oil change is not necessary. The gear units are executed **without vent plug**, there are no oil drain or oil level screws.. For special applications under difficult/aggressive ambient conditions, we recommend oil change after 10000 service hours, nevertheless.

Gear units of the model range C (from size 07), F (from size 06) and K (from size 06) need an **oil change** according to the **maintenance periods**. The gear units are executed with oil drain plugs/oil filling screws for the main mounting positions.

For special applications under difficult/aggressive ambient conditions, please contact your service partner!

ATEX!

- *No explosive atmosphere may be present in any maintenance or repair work. Maintenance and repair work must only be performed by qualified specialists in the field.*
- *The drive must be powered off during all maintenance work.*
- *The gear unit must be checked for leakage, especially the shaft seals and locking caps.*
- *Cleaning the drive: dust on the gear unit housing has to be removed on a regular basis.*
- *Check of the adapter's coupling star: Rubber parts of adapters need to be checked for abrasion. If the wearout is excessive, they need to be replaced (contact the producer).*

13.1. Inspection and maintenance intervals

Time interval	Inspection and maintenance work
monthly	<ul style="list-style-type: none"> ■ Gear units must be checked for noise changes (running noise of the gearing and rolling bearings) ■ Check the housing temperature (max. 90°C, 194°F) ■ Visible inspection of seals for leakage (Oil leakage) ■ Remove dust deposits
every 3 months	Clean the exterior of the vent plug
every half year	<ul style="list-style-type: none"> ■ Check the rubber buffer set ■ Check the fixing bolts to make certain they are tight
every 5000 service hours, no later than every 4 years	Visual check of the shaft seals; if applicable replace the shaft seals
every 10000 service hours, no later than every 5 years	Oil change: <ul style="list-style-type: none"> ■ Helical gear units C07, C08, C09, C10, C13, C14, C16 ■ Parallel shaft gear units F06, F07, F08, F09, F10, F12, F15 ■ Helical bevel gear units K06, K07, K08, K09, K10, K12, K15
every 10 years	General recovery
regularly on demand (depending on outside influences)	<ul style="list-style-type: none"> ■ Check the air gap ■ Clean the fan wheel of the motor

ATEX!

General overhaul:

The general overhaul is to be performed by the service team of the producer, where following actions are taken:

- *Outside cleaning of the housing.*
- *Disassembly and damage control of all parts.*
- *Replacement of damaged and wear parts, like shaft seals, locking caps and solid gaskets.*
- *Replacement of the coupling star and the vent plug.*
- *Replacement of the lubricant and the paint (if necessary)*
- *Final control*

13.2. Inspection and maintenance work on gear unit



WARNING!

No explosive atmosphere may be prevented in any maintenance or repair work. Maintenance and repair work must only be performed by qualified specialists in the field.

Maintenance and repair work are only to be carried out on a drive, which is in standstill with zero potential and secured against accidental switch on.



WARNING!

Before beginning the work let the gear cool down! Danger of burning!

Visible inspection of seals for leakage:

Make certain that no gear oil is leaking and that no oil traces can be found. In particular, the shaft seals and locking caps, as well as the sealing surface must be checked.

Check the rubber buffer set:

The rubber buffer set must be checked for visible damage, such as cracks on the surface, and they must be replaced in some cases.

Remove dust deposits:

Remove any layers of dust that have accumulated on the gear unit. If the gear unit design included a protection cap, remove it and clean it too. Then reinstall the protection cap (see page E-23).

Change the shaft seals:

When changing the shaft seal, make certain that, depending on the design, a sufficient deposit of grease is present between the dust lip and the sealing lip.

When using double seals, fill one-third of the space between them with grease.

Oil change:

Let the gear cool down before beginning with the work! The oil has to be warm to make a complete emptying easier (poor flow characteristics).

1. Put an appropriate container under the air vent and oil drain plug.
2. Remove the air vent and oil drain plug.
3. Let the oil drain completely.
4. Turn the plug in again completely.
5. Fill in the prescribed amount of oil over the vent plug (oil fill capacity see gear nameplate, permitted lubricants see page E-33).
6. Tighten the vent plug completely again.
7. Dispose the used oil according to applicable regulations.

General overhaul:

The general overhaul is to be performed by the producer or by an authorised service partner.

Adjustment of air gap: see Table 7 on page E-42.

Subsequent painting: If the gear unit is painted subsequently, shafts, shaft seals, mounting areas, rubber parts, vent plugs, oil gauge glasses, nameplates and stickers must stay clear of paint and solvents to avoid damage and keep important data readable.

14. Lubricants

If a special agreement regarding the lubricant is not reached, the gear units shall be delivered factory-filled (see table below marked grey). The specified gear fill amount and type is stated on the gear unit nameplate. The fill amount and oil type can be different at special applications.

The following lubricant table shows the lubricants that are approved for WG20 gear units.

For helical, parallel shaft and helical bevel gear units at ambient temperatures -10°C to +60°C (14°F to 140°F)

	ALPHA SP 220		Klüberoil GEM 1-220 N
	DEGOL BG 220		Mobilgear 600 XP 220
	Energol GR-XP 220		Omala S2 GX220
	Gear Oil 220 F		

Do not mix different types of lubricant!





Lubricants for other ambient conditions on request. Food proofed and biodegradable lubricants on request.

15. Mounting positions and lubricant capacity

15.1. Helical gear units C

Mounting positions and position of venting and oil drain screw - Housing in foot execution

By default, gear units are only equipped with venting and oil drain screw from gear size C07!

-  Position of the venting screw
-  Position of the oil drain screw
-  Position on this side
-  Position covered or on the opposite side

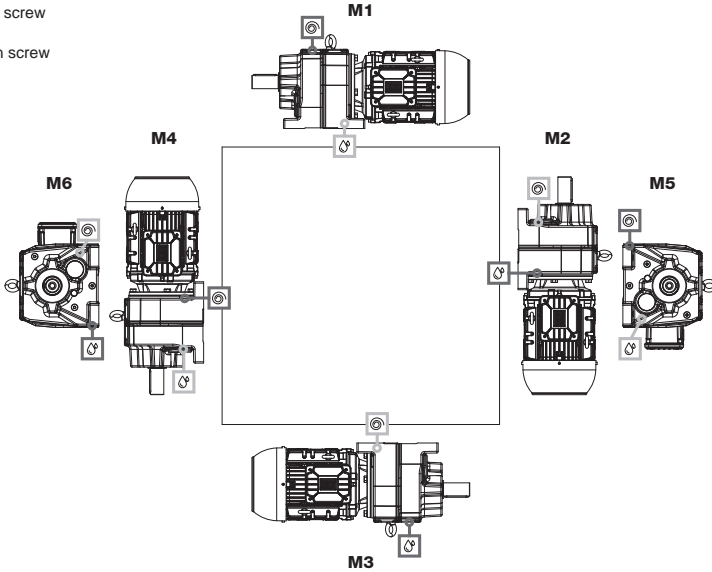

Lubricant capacity

Stages	Type with housing in foot execution	Mounting position					
		M1	M2	M3	M4	M5	M6
2	C00	0.1 l	0.3 l	0.3 l	0.3 l	0.2 l	0.2 l
	C01	0.1 l	0.4 l	0.4 l	0.3 l	0.3 l	0.3 l
	C03	0.3 l	0.7 l	0.6 l	0.6 l	0.5 l	0.4 l
	C05	0.4 l	1.2 l	1.1 l	1.2 l	0.8 l	0.7 l
	C06	0.5 l	1.6 l	1.6 l	1.5 l	1.1 l	1.0 l
	C07	1.6 l	3.8 l	3.6 l	4.6 l	2.8 l	2.4 l
	C08	3.4 l	7.1 l	6.7 l	8.9 l	4.7 l	5.4 l
	C09	10.0 l	13.5 l	13.0 l	15.5 l	10.5 l	12.5 l
	C10	14.5 l	21.0 l	16.5 l	22.5 l	14.5 l	18.5 l
	C13	24.0 l	34.0 l	29.0 l	37.5 l	26.0 l	28.5 l
	C14	36.0 l	49.0 l	43.5 l	56.0 l	36.5 l	44.0 l
	C16	64.5 l	92.5 l	77.5 l	98.5 l	64.5 l	75.5 l
3	C03	0.2 l	0.7 l	0.7 l	0.6 l	0.4 l	0.4 l
	C05	0.3 l	1.1 l	1.1 l	1.1 l	0.7 l	0.7 l
	C06	0.3 l	1.5 l	1.6 l	1.4 l	1.0 l	0.9 l
	C07	1.5 l	3.6 l	3.5 l	4.4 l	2.6 l	2.4 l
	C08	3.3 l	6.9 l	6.6 l	8.8 l	4.8 l	5.1 l
	C09	9.5 l	13.0 l	12.5 l	15.0 l	10.0 l	12.0 l
	C10	13.5 l	20.0 l	16.0 l	21.5 l	14.0 l	17.5 l
	C13	22.0 l	31.5 l	27.0 l	34.5 l	25.0 l	26.0 l
	C14	33.0 l	45.5 l	40.5 l	51.5 l	34.5 l	40.0 l
	C16	58.5 l	85.5 l	72.5 l	91.5 l	60.5 l	68.5 l

Mounting positions and position of venting and oil drain screw - Housing in flange execution

By default, gear units are only equipped with venting and oil drain screw from gear size C07!

- ⊙ Position of the venting screw
- ⊕ Position of the oil drain screw
- ◻ Position on this side
- ◻ Position covered or on the opposite side

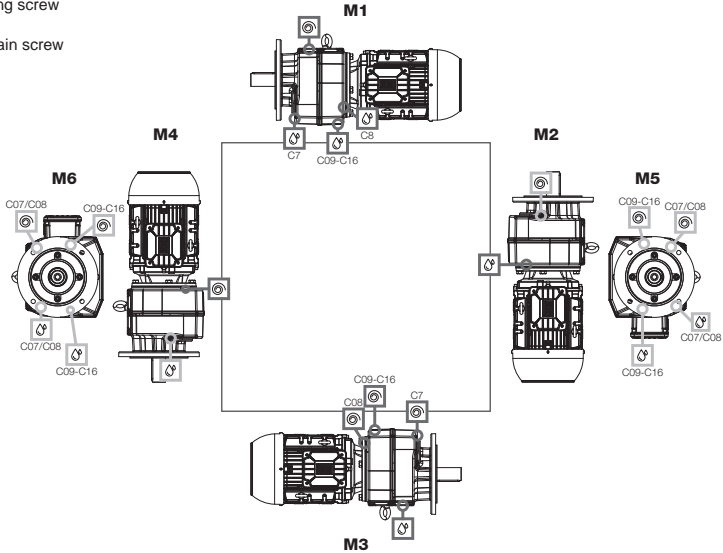





Lubricant capacity

Stages	Type with housing in flange execution	Mounting positions					
		M1	M2	M3	M4	M5	M6
2	C00	0.1 l	0.3 l	0.4 l	0.3 l	0.2 l	0.3 l
	C01	0.2 l	0.4 l	0.5 l	0.5 l	0.3 l	0.4 l
	C03	0.4 l	0.8 l	0.7 l	0.8 l	0.5 l	0.5 l
	C05	0.6 l	1.3 l	1.2 l	1.5 l	0.9 l	1.0 l
	C06	0.9 l	1.8 l	1.9 l	2.2 l	1.9 l	1.4 l
	C07	1.6 l	3.8 l	3.6 l	4.6 l	2.8 l	2.4 l
	C08	3.4 l	7.1 l	6.7 l	8.9 l	4.7 l	5.4 l
	C09	10.0 l	13.5 l	13.0 l	15.5 l	10.5 l	12.5 l
	C10	14.5 l	21.0 l	16.5 l	22.5 l	14.5 l	18.5 l
	C13	24.0 l	34.0 l	29.0 l	37.5 l	26.0 l	28.5 l
	C14	36.0 l	49.0 l	43.5 l	56.0 l	36.5 l	44.0 l
C16	64.5 l	92.5 l	77.5 l	98.5 l	64.5 l	75.5 l	
3	C03	0.3 l	0.7 l	0.7 l	0.7 l	0.5 l	0.5 l
	C05	0.5 l	1.2 l	1.3 l	1.5 l	0.9 l	1.0 l
	C06	0.8 l	1.7 l	1.8 l	2.1 l	1.2 l	1.3 l
	C07	1.5 l	3.6 l	3.5 l	4.4 l	2.6 l	2.4 l
	C08	3.3 l	6.9 l	6.6 l	8.8 l	4.8 l	5.1 l
	C09	9.5 l	13.0 l	12.5 l	15.0 l	10.0 l	12.0 l
	C10	13.5 l	20.0 l	16.0 l	21.5 l	14.0 l	17.5 l
	C13	22.0 l	31.5 l	27.0 l	34.5 l	25.0 l	26.0 l
	C14	33.0 l	45.5 l	40.5 l	51.5 l	34.5 l	40.0 l
	C16	58.5 l	85.5 l	72.5 l	91.5 l	60.5 l	68.5 l

15.2. Parallel shaft gear units F

Mounting positions and position of venting and oil drain screw

By default, gear units are only equipped with venting and oil drain screw from gear size F06!

-  Position of the venting screw
-  Position of the oil drain screw
-  Position on this side
-  Position covered or on the opposite side

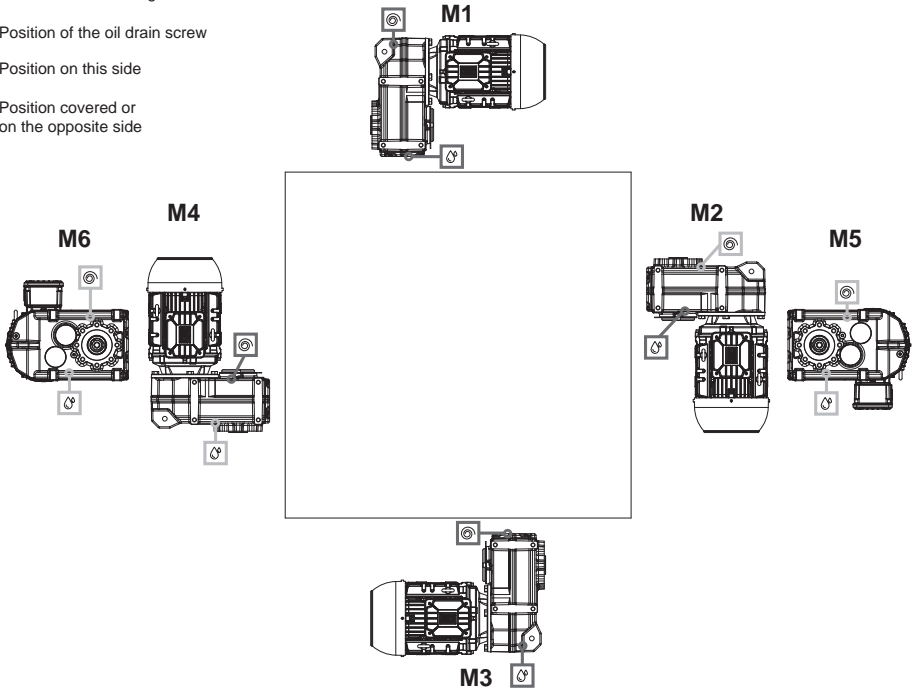

Lubricant capacity

Stages	Type	Mounting positions					
		M1	M2	M3	M4	M5	M6
2	F02	0.5 l	0.7 l	0.6 l	0.8 l	0.5 l	0.5 l
	F03	0.8 l	1.1 l	0.7 l	1.1 l	0.8 l	0.8 l
	F04	1.1 l	1.8 l	1.1 l	1.9 l	1.1 l	1.1 l
	F05	2.0 l	2.3 l	1.5 l	2.8 l	1.7 l	1.8 l
	F06	2.3 l	3.6 l	2.5 l	4.0 l	2.3 l	2.5 l
	F07	4.9 l	6.3 l	4.2 l	8.0 l	4.4 l	4.8 l
	F08	10.0 l	13.5 l	11.5 l	13.5 l	11.0 l	9.5 l
	F09	17.0 l	22.0 l	20.0 l	26.0 l	19.0 l	16.0 l
	F10	23.0 l	33.5 l	29.5 l	37.0 l	27.5 l	24.0 l
	F12	35.0 l	55.5 l	46.5 l	64.5 l	28.5 l	40.5 l
F15	60.0 l	105.0 l	88.0 l	100.5 l	50.5 l	75.5 l	
3	F04	1.5 l	1.7 l	1.1 l	1.8 l	1.0 l	1.1 l
	F05	2.3 l	2.2 l	1.4 l	2.5 l	1.6 l	1.5 l
	F06	2.7 l	3.5 l	2.3 l	3.8 l	2.4 l	2.3 l
	F07	5.8 l	6.2 l	3.9 l	7.7 l	4.4 l	4.5 l
	F08	8.5 l	14.5 l	12.5 l	15.0 l	7.0 l	10.5 l
	F09	16.0 l	24.0 l	21.5 l	28.0 l	13.5 l	18.0 l
	F10	22.0 l	36.5 l	32.5 l	41.0 l	19.5 l	27.5 l
	F12	36.5 l	51.0 l	42.5 l	58.5 l	40.5 l	35.5 l
	F15	69.0 l	101.5 l	83.0 l	108.5 l	78.5 l	71.5 l

15.3. Helical bevel gear units K

Mounting positions and position of venting and oil drain screw

By default, gear units are only equipped with venting and oil drain screw from gear size K06!

- ⊙ Position of the venting screw
- ⊕ Position of the oil drain screw
- ▣ Position on this side
- ◻ Position covered or on the opposite side

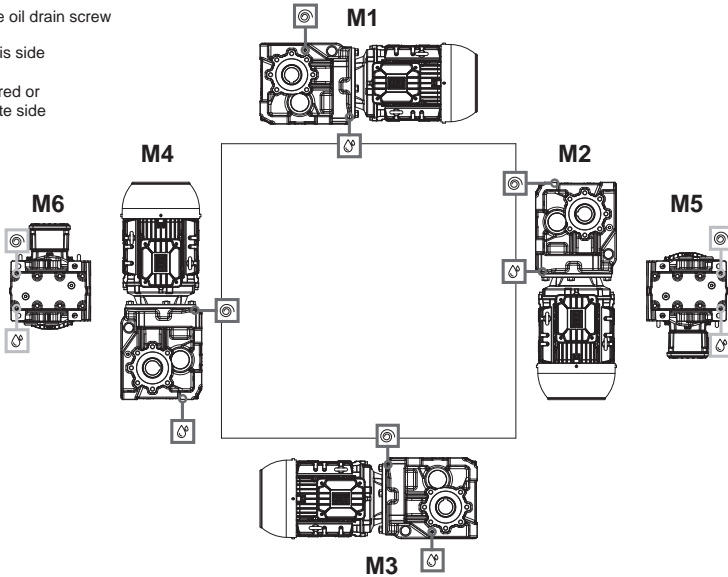

Lubricant capacity

Stages	Type	Mounting positions					
		M1	M2	M3	M4	M5	M6
2	K02	0.4 l	0.8 l	0.7 l	0.9 l	0.5 l	0.6 l
	K03	0.4 l	1.0 l	1.2 l	1.3 l	1.0 l	1.0 l
3	K04	0.6 l	1.6 l	1.9 l	2.1 l	1.7 l	1.7 l
	K05	0.8 l	2.1 l	2.6 l	3.1 l	2.1 l	2.2 l
	K06	0.8 l	2.0 l	2.7 l	3.0 l	2.2 l	2.4 l
	K07	1.5 l	3.5 l	4.3 l	5.3 l	3.7 l	4.1 l
	K08	3.2 l	7.0 l	8.0 l	9.2 l	7.2 l	7.6 l
	K09	5.8 l	11.5 l	13.0 l	16.6 l	15.6 l	15.6 l
	K10	9.1 l	18.3 l	21.8 l	26.6 l	24.7 l	24.8 l
	K12	16.3 l	26.4 l	28.8 l	41.4 l	34.7 l	36.2 l
	K15	28.0 l	50.6 l	65.0 l	79.5 l	71.8 l	71.1 l

16. Position of terminal box and cable entry

Figure 15: Possible terminal box positions 1 to 4 (standard position on side 1) and cable entries I to IV (standard position on side I)

C:

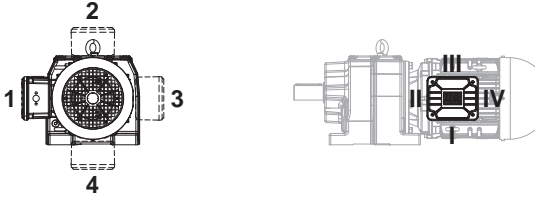

F:

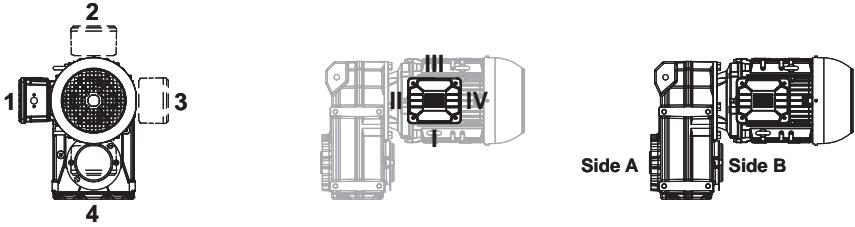

K:

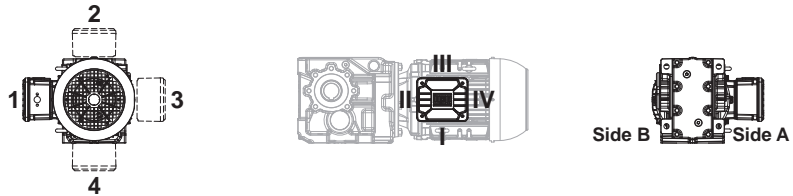

17. Terminal board connection

17.1. EUSAS Motors

Possible connection		Rated voltage series 11P (IEC 63 to 100)*		VSD operation	
		Rated power P_N	Increased rated power $1.2 \times P_N$		
	Delta	230 V at 50 Hz	-		400 V, 87 Hz
		265 V at 60 Hz	265 V at 60 Hz		
	Delta - Delta	115 V at 50 Hz	-		230 V, 100 Hz
		132 V at 60 Hz	132 V at 60 Hz		
	Star (Basic connection)	400 V at 50 Hz	-		400 V, 100 Hz
		460 V at 60 Hz	460 V at 60 Hz		
	Star - Star	200 V at 50 Hz	-		460 V, 120 Hz
		230 V at 60 Hz	230 V at 60 Hz		

Possible connection		Rated voltage series 11P, 22P (IEC 112 to 250)*		VSD operation	
		Rated power P_N	Increased rated power $1.2 \times P_N$		
	Delta (Basic connection)	400 V at 50 Hz	-		400 V, 100 Hz
		460 V at 60 Hz	460 V at 60 Hz		
	Delta - Delta	200 V at 50 Hz	-		460 V, 120 Hz
		230 V at 60 Hz	230 V at 60 Hz		
	Star	690 V at 50 Hz	-		460 V, 120 Hz
		-	-		
	Star - Star	346 V at 50 Hz	-		460 V, 120 Hz
		400 V at 60 Hz	400 V at 60 Hz		

17.2. Multi-Voltage Motors

Possible connection		Rated voltage series 14P (IEC 63 to 100)*		VSD operation	
		Rated power P_N	Increased rated power $1.2 \times P_N$		
	Delta	230 V at 50 Hz	-		400 V, 87 Hz
		265 V at 60 Hz	265 V at 60 Hz		
	Star (Basic connection)	400 V at 50 Hz	-		400 V, 100 Hz
		460 V at 60 Hz	460 V at 60 Hz		

* Tolerances of rated voltages in compliance with range A according to DIN EN 60034-1 (see Technical Catalogue)

17.3. Connection Diagram

Figure 16: Terminal board connection - Multi-Voltage Motor series

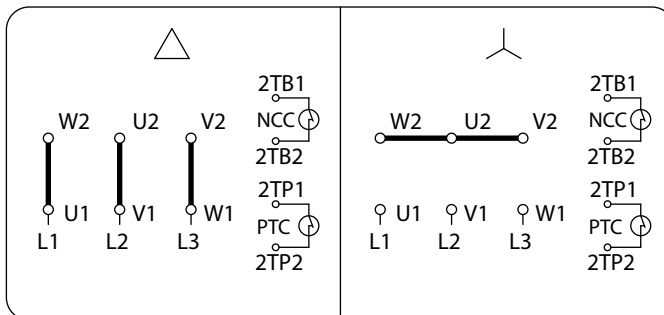
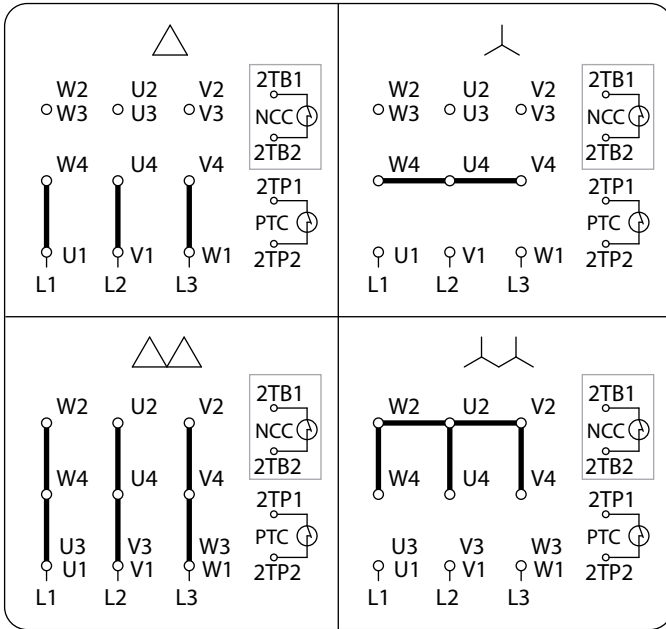

Figure 17: Terminal board connection - EUSAS Motor series 11P and 22P



Bimetal switch (2TB1/2TB2) only available for motor series 11

Table 5: Tightening torque for terminal box

Thread	Tightening torque M_a [Nm]
M4	0.7 - 1.0
M5	1.6 - 2.2
M6	2.2 - 3.5
M8	6 - 8
M10	10 - 14

18. Optional motor devices

Brake, encoder, temperature controller, anti-condensation heating, forced ventilation, etc. are present only on special order. Additional devices are to be connected according to the valid wiring diagrams.

18.1. Anti-condensation heating

Under certain climatic conditions, an anti-condensation heater may be required e. g. when there are great fluctuations in temperature or the motor is at rest in a humid atmosphere. For heater connection, see the motor terminal box.

WARNING!

Before energizing the motor, always make sure that the (optional) anti-condensation heating is switched off.

18.2. Drain

If motors are subject to great fluctuations in temperature or extreme climatic conditions, humid air can condense inside the machine. We recommend using a drain.

ATTENTION!

- *Open the drain depending on the environment and operating conditions. Afterwards, close the drain plug.*
- *Before installing motors with drain, check that the mounting position is correct!*

Figure 18: Detail of the drain plug position on drive endshield

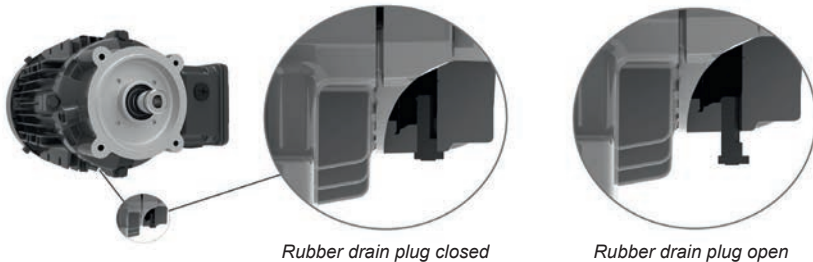

18.3. Forced cooling

ATTENTION!

- *The forced cooling must be connected according to the wiring diagram below (see also in forced cooling terminal box).*
- *If the motor is operated with a frequency inverter, it's not allowed to connect the forced cooling to the frequency inverter. Connect the forced cooling to an EXTERNAL power supply.*

Table 6: Voltage range forced cooling

IEC frame size	Phases / Connection	Voltage range [V]	
		50 Hz	60 Hz
63 - 250	3~ / Star	346 - 525	380 - 575
	3~ / Delta	200 - 303	220 - 332
	1~ / Delta Steinmetz	230 - 277	230 - 277

Star Connection

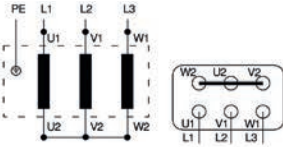

U1 = black
U2 = green

V1 = light blue
V2 = white

Delta Connection

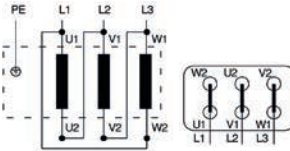

W1 = brown
W2 = yellow

Delta Steinmetz Connection

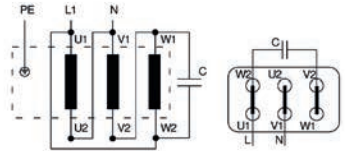

18.4. Temperature controller Bimetal switch „NC contact“ (TH)

Thermostats have small bimetallic strips that make or break a contact when the critical temperature is reached. The break contact opens the field circuit and disconnects the power supply to the motor. **Thermostats are only available for motor series 11 (frame sizes 63 to 132).**

Block terminal designation in the terminal box: 2TB1 / 2TB2 (see page E-40)

18.5. PTC Thermistor protection (TF)

PTC thermistors are semi-conductors whose electrical resistance increases dramatically when the critical temperature is reached.

In addition to the PTC thermistor, a control unit is also required. The relay in the tripping unit has a changeover contact, which can either be used to open the excitation circuit in the motor contactor or trigger a warning signal.

Block terminal designation in the terminal box: 2TP1 / 2TP2 (see page E-40)

18.6. Brake

ATEX!

For detailed information on the use of brakes in explosion-protected areas, please refer to the brake operating manual (manufacturer Intorq), if supplied. Instructions for installation, operation and maintenance must be strictly observed.

The brakes must not be used in dust group IIIC (conductive dusts).

The single-disc brake is released electrically. The brake is applied mechanically when the voltage is switched off.

At delivery the brakes are adjusted to the brake torque.

Connecting the brake:

Connect the brake control system according to the circuit diagram supplied with the brake.

Maintenance:

The spring-loaded brakes hardly need any maintenance. The air gap "a" must be checked periodically to ensure safe brake release. Adjust air gap "a" to the figures given in Table 7 if necessary.

Table 7: Air gap of operating brake

Brake size		BR2	BR4	BR5	BR8	BR10	BR16	BR20	BR32	BR40	BR60	BR100	BR150	BR250	BR400
a (normal)	[mm]	0.2	0.2	0.2	0.2	0.2	0.2	0.3	0.3	0.3	0.3	0.4	0.4	0.5	0.5
a (maximum)	[mm]	0.6	0.5	0.6	0.5	0.7	0.5	0.8	0.75	0.9	1.0	1.1	1.1	1.2	1.2

Adjustment of the air gap (see Figure 19 on page E-43):

1. Loosen the three fixing bolts (11) in a half turn.
2. Turn the hollow screws (9) counter-clockwise into the magnetic case (10).
3. Turn the three fixing bolts (11) clockwise until the nominal air gap (see Table 7) between the magnetic case (10) and armature disc (8) is reached.
4. Turn the three hollow screws (9) again clockwise out of the magnetic case (10) and retighten the fixing bolts (11). Control the air gap "a" with a feeler gauge on evenness and make a correction if necessary.

Figure 19: Exploded view brake

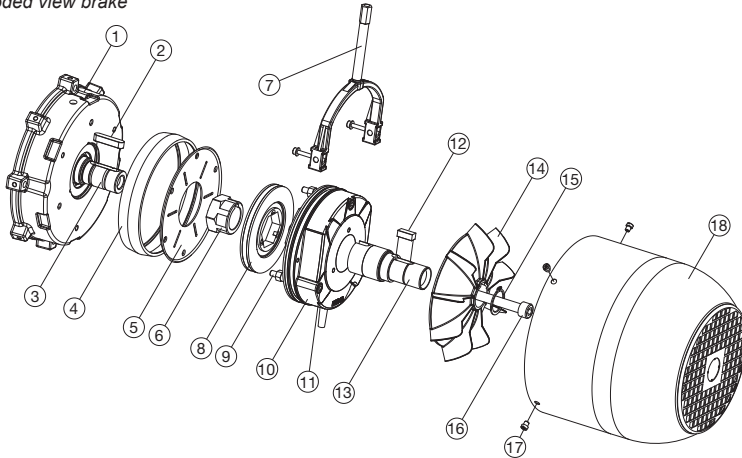

- | | | | |
|-----|----------------------------------|------|-----------------------------|
| (1) | Brake endshield | (10) | Magnetic case |
| (2) | Key | (11) | Socket cap screws |
| (3) | Motor shaft | (12) | Key |
| (4) | Dust protection ring | (13) | Brake shaft extension |
| (5) | Friction plate | (14) | Fan |
| (6) | Gear hub | (15) | Retaining ring |
| (7) | Manual release lever (optional) | (16) | Socket cap screw |
| (8) | Brake disc with friction linings | (17) | Fan cover screws |
| (9) | Sleeve screws | (18) | Fan cover (brake execution) |

18.6.1. Manual brake release

It is used to lift the brake in case of a loss of power supply. By pressing the lever, the anchor plate is pulled to the magnet and the brake is lifted.

ATTENTION!

For safety reasons the adjustment of the manual release must not be changed.

18.6.2. Locking device for the manual release lever

In case of service, the manual brake release can be fixed with a locking device.

ATTENTION!

The motor may only be taken into operation after having deactivated the locking device.

18.6.3. Rectifier

Brake motors will be delivered as standard with connected rectifier for AC-side switching. For DC-side switching the bridge between terminals 5 and 6 must be removed and a switching contact must be connected.

ATTENTION!

Start-up of motor only with connected brake. (Check!)

ATEX!

If geared motors with brakes are used in potentially explosive areas (zone 2 + 22), the rectifiers must be installed outside the EX area.

The rectifiers must not be installed in the motor terminal box.

Figure 20: Rectifier

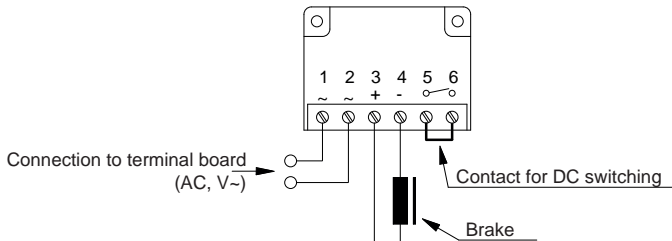

Power supply:

The DC brake coil is normally supplied with power from a rectifier installed in the motor terminal box. The rectifiers are equipped with varistors to protect them against overvoltage. Max. ambient temperature for rectifiers is +80 °C. For starting frequency above 1/s, contact us for rectifier loading capacity!

The braking system is connected with a rectifier installed in the terminal box in accordance with the enclosed circuit diagram.

Half-wave rectifier (standard version) - Connection:

- AC voltage 100% e.g. 400 V~
- DC voltage 45% e.g. 180 V=

Bridge rectifier - Connection:

- AC voltage 100% e.g. 230 V~
- DC voltage 90% e.g. 207 V=

ATTENTION!

If a brake motor is operated with a frequency converter, connect the brake coil to an external power supply.

18.6.4. Encoder

This encoder is a precision measuring instrument. Always observe the information and instructions of the datasheet to ensure trouble-free function and to maintain warranty claims.

Please observe absolutely the following points:

- It is not permissible to dismantle the encoder entirely or in part or to modify it.
- Do not alter the shaft (by grinding, sawing, drilling, etc.), otherwise the accuracy of the encoder and the reliability of bearing and seal will suffer.
- Never align the instrument with a hammer.
- It is imperative to avoid impact loads.
- Observe maximal radial and axial loads to the encoder shaft under any circumstances.
- Do not connect encoder and drive rigidly to one another at shafts and flanges.
- Never use the assembled encoder to lift the drive-unit.
- Never step onto the encoder.

Technical Data Standard Encoder:

Type	Voltage	Pulses	Output signal
Kübler 5020	10 - 30 V	1024	HTL
Kübler A02H (Heavy Duty)	10 - 30 V	1024	HTL

Table 8: Pin definition standard encoder:



SIGNAL		GRD	B _{INV}	+ UB Sens	0	0 _{INV}	A	A _{INV}	-	B	-	0 V	0 V Sens	+UB	U _{AS}
KÜBLER	M23 x 1 Can		1	2	3	4	5	6	7	8	9	10	11	12	-
	PVC cable	PH	PK	BU/RD	BU	RD	GN	YE	-	GY	-	WH	GY/PK	BN	-
	PUR cable HT cable	PH	PK	BN*	BU	RD	GN	YE	-	GY	-	WH°	WH*	BN°	-

Code	Colour	Code	Colour	Code	Colour	Code	Colour	Code	Colour
BK	Black	GN	Green	RD	Red	YE	Yellow	PH	Shield is attached to connector housing
BN	Brown	GY	Grey	VT	Violet	*	Thin cable		
BU	Blue	PK	Pink	WH	White	°	Thick cable		

19. Table of Tightening Torques

Screw connections are laid out for screw property class 8.8:

Table 9: Tightening Torques

Tightening torque Ma [Nm] - tolerance +10 %			
Thread	Screw property class 8.8	Screw property class 10.9	Screw property class 12.9
M5	5.5	8.0	10
M6	10	14	18
M8	25	33	43
M10	45	65	80
M12	75	105	135
M16	190	270	340
M20	380	530	670
M24	650	900	1150
M30	1300	1800	2300

20. Disposal

Mind the current national regulations for the disposal.

Oils and greases or oil and grease containing wastes make up a high hazardous potential for the environment. Thus, ensure a professional disposal!

Geared motors units	Material
Gear housing, housing parts (input cover, adapters, flanges etc.)	Aluminium, Grey cast iron
Gear inner parts (tooth wheels, keys, shafts)	Steel
Shaft sealing rings	Elastomer with steel
Flat seals	Asbestos-free
Gear oil	Additivated mineral oil

21. Declaration of incorporation

Declaration of Incorporation

in terms of the EC Machinery Directive 2006/42/EC, Annex II B



Product:

- Helical geared motors WG20
- Parallel shaft geared motors WG20
- Helical bevel geared motors WG20

Classification:

C.
F.
K.

Producer:

WATT DRIVE Antriebstechnik GmbH
Wöllersdorfer Straße 68
2753 Markt Piesting - Austria

Authorised person for the compilation of the technical documents:

Norbert Reisner - Wöllersdorfer Straße 68 - 2753 Markt Piesting - Austria

The producer herewith declares referring to the above named incomplete machines that:

- They meet the basic requirements of the Directive 2006/42/EC as far as possible.
- The technical documents have been compiled according to Annex VII Chapter B.
- The special technical documents for partly completed machinery have been created and can be made available to the national authorities in response to a reasonable request .
- Their commissioning is prohibited until they have been implemented according to the mounting instruction and an EC Declaration of Conformity for the whole machine according to Directive 2006/42/EC.

Relevant applicable provisions:

- | | |
|--------------------------------|--|
| ■ EC Machinery Directive | 2006/42/EC |
| ■ Security for Machinery | EN ISO 12100:2010 |
| ■ Electric Equipment | EN 60204 -1:2006 + A1:2009 + AC:2010 |
| ■ Separating Safety Equipment | EN ISO 14120:2015 |
| ■ Safety Distances | EN ISO 13857:2008 |
| ■ Rotating Electrical Machines | |
| | EN 60034-1:2010 + AC:2010, EN 60034-2-1:2007, EN 60034-5:2001 + A1:2007, |
| | EN 60034-6:1993, EN 60034-7:1993 + A1:2001, EN 60034-8:2007 + A1:2014, |
| | EN 60034-9:2005 + A1:2007, EN 60034-11:2004, EN 60034-12:2002 + A1:2007, |
| | EN 60034-14:2004 + A1:2007, EN 60034-30:2009 |

The original version of the mounting instruction belonging to the incomplete machine is in German.

Markt Piesting, April 26, 2017

Place and date of issue

Klaus Sirrenberg - Managing Director

22. EU declaration of conformity ATEX 2014/34/EU

EU - Declaration of Conformity

in terms of the EU Directive on Explosion Protection 2014/34/EU



Products of the geared motor series WG20/MAS:

- Helical geared motors
- Shaft mounted geared motors
- Parallel shaft geared motors
- Helical worm geared motors
- Helical bevel geared motors
- Angle parallel shaft geared motors

Classification:

C./H.
- /A.
F./F.
- /S.
K./K.
- /C.

Producer:

WATT DRIVE Antriebstechnik GmbH
Wöllersdorfer Straße 68
2753 Markt Piesting - Austria

The manufacturer declares the sole responsibility for the above-mentioned products for::

- Zone 2 and 22
- Device Group II
- Category 3G and 3D

Marking:

- II 3G Ex h IIC T4 Gc / II 3G Ex ec IIC T3 Gc
- II 3D Ex h IIIC T125°C Dc / II 3D Ex tc IIIC T125°C Dc

Applied harmonised standards:

- EN 80079-36:2016
- EN 80079-37:2016
- EN 60079-0:2012
- EN 60079-15:2010
- EN 60079-31:2014

Markt Piesting, October 17, 2018

Place and date of issue

Klaus Sirrenberg - Managing Director

EU - Declaration of Conformity

in terms of the EU Directive on Explosion Protection 2014/34/EU



Products of the gear unit series WG20/MAS:

- Helical gear unit with motor adapter or input shaft
- Shaft mounted gear unit with motor adapter or input shaft
- Parallel shaft gear unit with motor adapter or input shaft
- Helical worm gear unit with motor adapter or input shaft
- Helical bevel gear unit with motor adapter or input shaft
- Angle parallel shaft gear unit with motor adapter or input shaft

Classification:

- C./H.
- /A.
- F./F.
- /S.
- K./K.
- /C.

Producer:

WATT DRIVE Antriebstechnik GmbH
Wöllersdorfer Straße 68
2753 Markt Piesting - Austria

The manufacturer declares the sole responsibility for the above-mentioned products for:

- Zone 1 and 21, Device Group II, Category 2G and 2D
- Zone 2 and 22, Device Group II, Category 3G and 3D

Marking:

- II 2G Ex h IIC T4 Gb
- II 2D Ex h IIIC T125°C Db
- II 3G Ex h IIC T4 Gc
- II 3D Ex h IIIC T125°C Dc

Applied harmonised standards:

- EN 80079-36:2016
- EN 80079-37:2016

WATT DRIVE Antriebstechnik GmbH deposits the required documents according to 2014/34/EU at the notified body:

TÜV Austria, No. 0408

Markt Piesting, February 18, 2020

Place and date of issue

Klaus Sirrenberg - Managing Director

EU - Declaration of Conformity

in terms of the Low Voltage Directive 2014/35/EU



Product:

- Asynchronous Three Phase motors with cage rotor
- Single Phase Induction motor with cage rotor

IEC Motor Size: 56 - 355

Series:

WA_	7WA_	70 WA_	7B WA_	2A WA_	2B WA_	3A WA_	3B WA_	3C WA_
WP_	7WP_	70 WP_	7B WP_	2A WP_	2B WP_	3A WP_	3B WP_	3C WP_
11N	11H	11P	11S	22P	22S	M31_	M32_	M33_

Producer:

WATT DRIVE Antriebstechnik GmbH
Wöllersdorfer Straße 68
2753 Markt Piesting - Austria

This declaration of conformity is issued under the sole responsibility of the manufacturer.

The object of the declaration described above is in conformity with the relevant Union harmonisation legislation:

- Low Voltage Directive 2014/35/EU
- ErP Directive 2009/125/EG ¹⁾
- EMC Directive 2014/30/EU
- Electrical Equipment EN60204-1:2006 + A1:2009 + AC:2010, EN 60204-11:2000 + AC:2010
- Rotating Electrical Machines
EN 60034-1:2010 + AC:2010, EN 60034-2-1:2007, EN 60034-5:2001 + A1:2007,
EN 60034-6:1993, EN 60034-7:1993 + A1:2001, EN 60034-8:2007 + A1:2014,
EN 60034-9:2005 + A1:2007, EN 60034-11:2004, EN 60034-12:2002 + A1:2007,
EN 60034-14:2004 + A1:2007, EN 60034-30:2009

¹⁾ Products that are covered by this ErP Directive meet the requirements of Regulation (EC) No. 640/2009 from July 22 resp. Regulation (EU) No. 4/2014 from January 6, 2014.

Markt Piesting, February 14, 2019

Place and date of issue

Klaus Sirrenberg - Managing Director



Watt Drive Antriebstechnik GmbH – WEG Group

Wöllersdorfer Straße 68, 2753 Markt Piesting, Austria

Phone: +43 (0)2633 / 404-0, Fax: +43 (0)2633 / 404-220

E-Mail: info-at@weg.net

Web: www.wattdrive.com

Code: 50069628 | Rev.: 06 | Date (M/J): 06/2021

Language: English, Original document: German

The values shown are subject to change without prior notice.